



## Teileliste und Näheinrichtungen Spare Parts List and Sewing Equipment

# 467

**DÜRKOPP ADLER AG**

---

Postfach 17 03 51, D-33703 Bielefeld • Potsdamer Straße 190, D-33719 Bielefeld  
Telefon (05 21) 9 25-0 • Telefax (05 21) 9 25 24 35

---

Ausgabe / Edition: 01/90 • DO

Printed in Federal Republic of Germany

Teile-/Part-No.: 0791 467801



Näheinrichtungen

Sewing Equipment

467

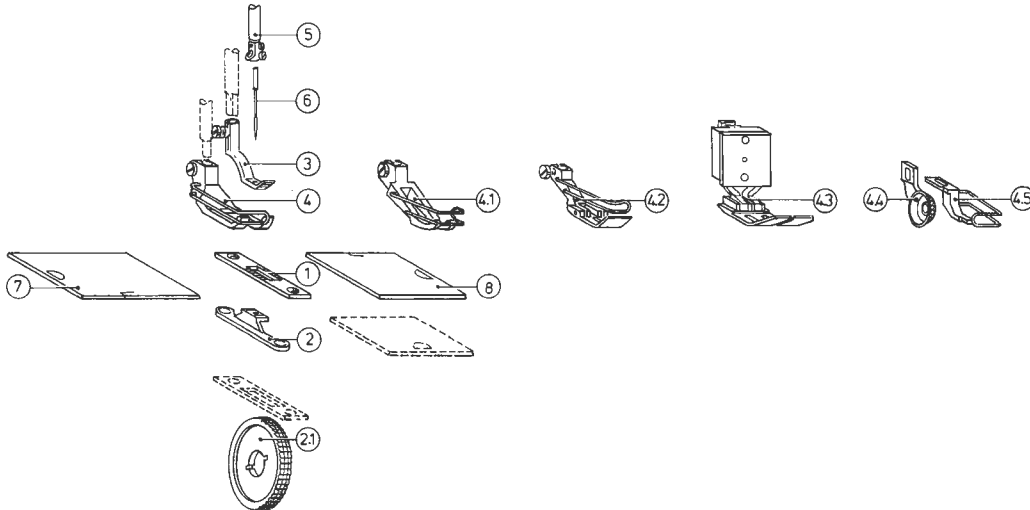

- |                             |                          |                                  |                             |
|-----------------------------|--------------------------|----------------------------------|-----------------------------|
| ① Stichplatte               | ① Needle plate           | ① Plaque à aiguilles             | ① Placa de aguja            |
| ② Transporteur              | ② Feed                   | ② Transporteur                   | ② Transportador             |
| ②.1 Radtransporteur         | ②.1 Roller feed          | ②.1 Roue à transport             | ②.1 Transportador de rueda  |
| ③ Transportfuß              | ③ Feed foot              | ③ Transporteur                   | ③ Pie transporteur          |
| ④ Fester Fuß (Drückerfuß)   | ④ Fixed foot             | ④ Pied transporteur (presseur)   | ④ Pie fijo (pie prensatela) |
| ④.1 Fester Fuß (Kletterfuß) | ④.1 Climbing foot        | ④.1 Pied transporteur (grimpeur) | ④.1 Pie fijo (pie trepador) |
| ④.2 Gelenkfuß               | ④.2 Hinged foot          | ④.2 Pied articulé                | ④.2 Pie articulado          |
| ④.3 Ausgleichfuß            | ④.3 Equalising foot      | ④.3 Pied égalisateur             | ④.3 Pie compensador         |
| ④.4 Rollfuß                 | ④.4 Roller foot          | ④.4 Pied à roulettes             | ④.4 Pie de rodillo          |
| ④.5 Niederhalter            | ④.5 Press pad            | ④.5 Presse-tôle                  | ④.5 Aprieta-cuero           |
| ⑤ Nadelstange               | ⑤ Needle bar             | ⑤ Bare à aiguilles               | ⑤ Barra de aguja            |
| ⑥ Nadel                     | ⑥ Needle                 | ⑥ Aiguille                       | ⑥ Aguja                     |
| ⑦ Schieber links            | ⑦ Left-hand slide plate  | ⑦ Pousoir de gauche              | ⑦ Placa corrediza izquierda |
| ⑧ Schieber rechts           | ⑧ Right-hand slide plate | ⑧ Pousoir de droite              | ⑧ Placa corrediza derecha   |

1. Die Garniturenliste wurde in Gruppen aufgeteilt und diese mit grossen Buchstaben gekennzeichnet

The list of sewing components is arranged in groups of parts, each marked with a large letter

La liste de garniture a été divisée en groupes qui ont été désignés par lettres magiques

La lista de juegos de costura fue dividida en grupos, siendo marcados éstos con letras mayúsculas.

2. NA ≙ Nahtabstand

NA ≙ seam spacing   
 Relationship of needle thickness to the sub-classes

NA ≙ distance entre deux coutures   
 Relation entre la grosseur d'aiguille et les différentes sous-classes

NA ≙ distancia entre costuras   
 Agregación del grosor de aguja a los submodelos

Nadelstärke	Unterklassen 367.../ 467...							
70 - 90	-	-	- 61 S	- 261	-	-	-	- 81 S
90 - 110	2 S	- 202 S	- 62 S	- 262	- 72	- 372	- 272	- 82 S
110 - 140	3 S	- 203 S	- 63 S	- 263	- 73	- 373	- 273	- 83 S
140 - 180 (200)	4 S	- 204 S	- 64 S	- 264	- 74	- 374	- 274	- 84 S

4. Schneidabstand SA

Cutting - distance SA

Distance de coupe SA

SA

5. ● vor einer Unterklasse ≙  
 Garnitur auf Wunsch für bestimmte Einsatzzwecke, wobei Einzelteile auch in der Grundklasse sein können.

● Before a sub-class ≙  
 Sewing components for special requirements on request, whereby certain parts may be included in the basic equipment

● Devant une sous-classe ≙  
 Garniture sur demande pour certains cas d'utilisation, où il est possible que certaines pièces se trouvent également dans la classe principale.

● Delante de un submodelo ≙  
 a deseo juego de costura para trabajos determinados, del cual piezas sueltas pueden encontrarse en el modelo base.

6. ○ Hinter einer Teile Nr. ≙  
 Teil auf Wunsch für bestimmte Einsatzzwecke

○ Behind a part number ≙  
 Part available on request for special requirements.

○ Après une pièce ≙  
 Pièce sur demande, pour certains cas d'utilisation.

○ Detras de un número de repuesto ≙  
 a deseo repuesto para trabajos determinados.

7. ▲   
 Garnitureneinzerteile u. Befestigungsschrauben siehe Bildtafel. ①

▲   
 Individual sewing component parts and fixing screws; see illustration. ①

▲   
 Pièces de garniture et vis de fixation: voir planche ①

▲   
 Piezas de juego de costura y tornillo de fijación: vease la pagina ilustrada ①

8. /N 4,5; 6; 9 = Stichlänge

/N 4,5; 6; 9 = Stichlength

/N 4,5; 6; 9 = Longueur de point

/N 4,5; 6; 9 = Longitud de puntada.

9. Teile-Nr. ohne Kennzeichnung sind Grundteile.

Part numbers without a symbol are basic parts.

No. de pièces sans symbol = des pièces de base.

No. de piezas sin simbolo son piezas de base.

10. V = veraltet

V = obsolete

V = ancien model

V = Viejo modelo

Unterklassen laut Verkaufsprogramm  
 Sub-Classes as in Sales programme

Unterklasse: Sub-Class:	Einrichtungs-Nr. : equipment-No. :	Gruppe: Group:	Unterklasse: Sub-Class:	Einrichtungs-Nr. : equipment-No. :	Gruppe: Group:	Unterklasse: Sub-Class:	Einrichtungs-Nr. : equipment-No. :	Gruppe: Group:
467-73-G2	K467-E12	C0	467-PA-74-G2	K767-E8	C0	467-VF-373/N6	K467-E10	C1
-FA-73-G2			-FA-374-G2			467-LG-73	K467-E14	C2
467-VF-373/N6	K467-E11	C1	467-LGF-73/N6	K467-E5	C2	-LGF-73-G2		
467-LG-74	K467-E6	C2	467-AB-73/N6	K467-E15	C2	467-AB-73/N6	K467-E7	C2
-LG-74-G2			467-AB-73/N6	K467-E9	C2	467-FA-273-G2	K767-E21	F0
467-AB-73/N6	K467-E8	C2						

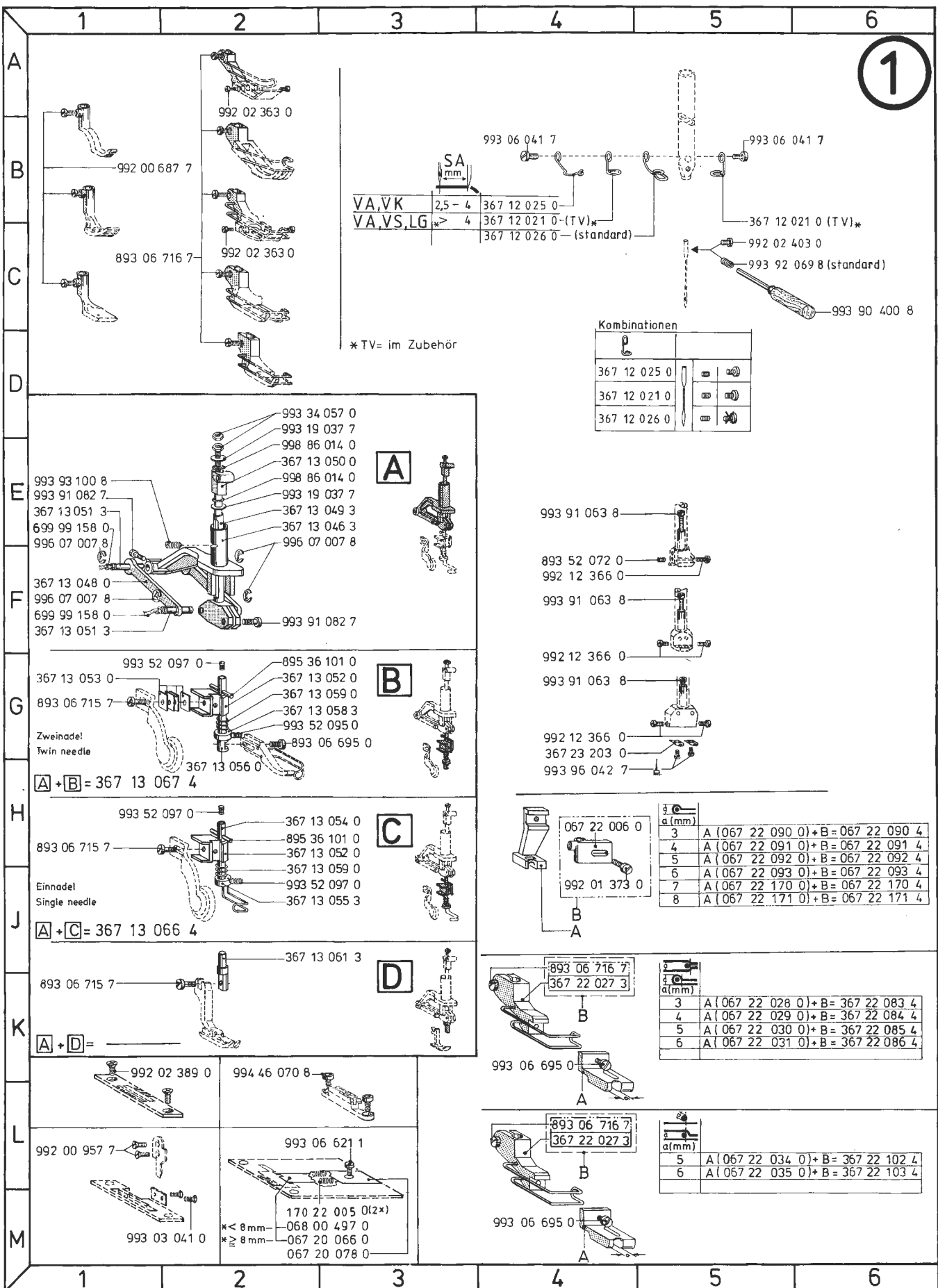

VA, VK	2,5 - 4	367 12 025 0
VA, VS, LG	* > 4	367 12 021 0 - (TV)*
		367 12 026 0 - (standard)

\* TV= im Zubehör

Kombinationen

ℓ	
367 12 025 0	
367 12 021 0	
367 12 026 0	

**E**

993 93 100 8  
993 91 082 7  
367 13 051 3  
699 99 158 0  
996 07 007 8

993 34 057 0  
993 19 037 7  
998 86 014 0  
367 13 050 0  
998 86 014 0  
993 19 037 7  
367 13 049 3  
367 13 046 3  
996 07 007 8

**A**

**F**

367 13 048 0  
996 07 007 8  
699 99 158 0  
367 13 051 3

993 91 082 7

**G**

993 52 097 0  
367 13 053 0  
893 06 715 7

895 36 101 0  
367 13 052 0  
367 13 059 0  
367 13 058 3  
993 52 095 0  
893 06 695 0

Zweinadel  
Twin needle

367 13 056 0

**A** + **B** = 367 13 067 4

**B**

**H**

993 52 097 0  
893 06 715 7

367 13 054 0  
895 36 101 0  
367 13 052 0  
367 13 059 0  
993 52 097 0  
367 13 055 3

Einnadel  
Single needle

**A** + **C** = 367 13 066 4

**C**

**J**

893 06 715 7

367 13 061 3

**A** + **D** = \_\_\_\_\_

**D**

992 02 389 0

994 46 070 8

992 00 957 7

993 06 621 1

170 22 005 0 (2\*)

\* < 8 mm - 068 00 497 0  
≥ 8 mm - 067 20 066 0  
067 20 078 0

993 03 041 0

\* < 8 mm - 068 00 497 0  
≥ 8 mm - 067 20 066 0  
067 20 078 0

993 91 063 8

893 52 072 0  
992 12 366 0

993 91 063 8

992 12 366 0

993 91 063 8

992 12 366 0  
367 23 203 0  
993 96 042 7

067 22 006 0

992 01 373 0

**B**

**A**

ℓ	a (mm)	
3		A (067 22 090 0) + B = 067 22 090 4
4		A (067 22 091 0) + B = 067 22 091 4
5		A (067 22 092 0) + B = 067 22 092 4
6		A (067 22 093 0) + B = 067 22 093 4
7		A (067 22 170 0) + B = 067 22 170 4
8		A (067 22 171 0) + B = 067 22 171 4

893 06 716 7

367 22 027 3

**B**

**A**

ℓ	a (mm)	
3		A (067 22 028 0) + B = 367 22 083 4
4		A (067 22 029 0) + B = 367 22 084 4
5		A (067 22 030 0) + B = 367 22 085 4
6		A (067 22 031 0) + B = 367 22 086 4









893 06 716 7











367 22 027 3

**B**





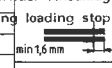

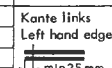
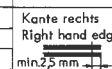
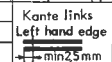





**A**

ℓ	a (mm)	
5		A (067 22 034 0) + B = 367 22 102 4
6		A (067 22 035 0) + B = 367 22 103 4

A	B	C	D	E	F	G	H	J	K	L	M	N	O
Einnadel feststehend Fixed single needle												Gruppe: Nr. <b>A.0</b> Group:	
E-Nr.:	<b>467</b>												
1													
2		-25/N4,5,6	367 20 001 0	367 21 001 0	-	067 22 600 4	367 12 020 4	134 Lr/100	367 14 207 0	367 14 009 0			
3		FA-25/N4,5,6											
4													
5													
6													
7													
8													
9													
10		-35/N6,4,5	367 20 005 0	367 21 001 0	-	067 22 602 4	367 12 020 4	134 Lr/130	367 14 207 0	367 14 009 0			
11		FA-35/N6,4,5											
12													
13													
14													
15													
16													
17													
18		-45/N6,4,5	467 20 003 0	467 21 003 0	-	067 22 602 4	367 12 020 4	134 Lr/100	367 14 207 0	367 14 009 0			
19		FA-45/N6,4,5											
20													
21													
22													
23													
24													
25													
26													
27													
28													
29													
30													
31													
32													
33													
34													
35													
36													
37													
38													
39													
40													

A	B	C	D	E	F	G	H	J	K	L	M	N	O
Einnadel mit Nadeltransport Single needle with needle feed												Nr. <b>B.0</b>	
	<b>467</b>												
41													
42													
43													
44													
45													
46													
47													
48													
49													
50													
51													
52													
53													
54													
55													
56													
57													
58	⊙	-62N 4,5; 6				367 22 106 4							
59	⊙	FA-62N 4,5; 6											 federnder Anschlag spring loading stop min 1,6 mm
60													
61													
62		-62/N4,5; 6	367 20 002 0	367 21 002 0	367 22 001 4	-	367 12 020 4	134 cr/100	367 14 207 0	367 14 009 0			
63		FA-62/N4,5; 6											
64													
65													
66		-62S/N4,5; 6	367 20 002 0	367 21 002 0	-	067 22 601 4	367 12 020 4	134 cr/100	367 14 207 0	367 14 009 0			
67		FA-62S/N4,5; 6											
68													
69													
70													
71													
72	⊙	-62/N4,5; 6				367 22 055 3							 Kante rechts Right hand edge min 2,5 mm
73	⊙	FA-62/N4,5; 6											
74													
75	⊙	-62/N4,5; 6				367 22 061 3							 Kante links Left hand edge min 2,5 mm
76	⊙	FA-62/N4,5; 6											
77													
78													
79													
80													
81		-63/N6	367 20 002 0	367 21 005 0	367 22 001 4	-	367 12 020 4	134 cr/120	367 14 207 0	367 14 009 0			
82		FA-63/N6											
83													
84		-63S/N6	367 20 002 0	367 21 005 0	-	067 22 602 4	367 12 020 4	134 Lr/130	367 14 207 0	367 14 009 0			
85		FA-63S/N6											
86													
87	⊙	-63/N6				367 22 055 3							 Kante rechts Right hand edge min 2,5 mm
88	⊙	FA-63/N6											
89													
90	⊙	-63/N6				367 22 061 3							 Kante links Left hand edge min 2,5 mm
91	⊙	FA-63/N6											

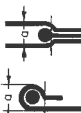
KH. 7.80 ⊙ Teil auf Wunsch für bestimmte Einsatzzwecke ● Garnitur auf Wunsch für bestimmte Einsatzzwecke, wobei Einzelteile auch in der Grundklasse sein können. ▲ Einzelteile siehe Blatt ①  
 JT.9.95 ⊙ TV-Teil nur als Ersatz lieferbar  
 KH.8.89

A	B	C	D	E	F	G	H	J	K	L	M	N	O
Einnadel mit Nadeltransport Single needle with needle feed												Gruppe: Nr. <b>B.1</b> Group:	
E-Nr.: <b>467</b>													
1		-63/N9		367 20 019 0	367 21 005 0	367 22 047 4	-	367 12 020 4	134 / 120	367 14 207 0	367 14 009 0		
2		FA-63/N9											
3													
4													
5	⊙	-63/N9											Kante rechts Right hand edge
6	⊙	FA-63/N9											min. 2,5 mm
7													
8	⊙	-63/N9											Kante links Left hand edge
9	⊙	FA-63/N9											min. 2,5 mm
10													
11		-63/N12		367 20 032 0	367 21 005 0	367 22 075 4	-	367 12 020 4	134 / 120	367 14 207 0	367 14 009 0		
12													
13													
14		-64/N6		367 20 002 0	467 21 002 0	367 22 001 4	-	367 12 020 4	134 / 150	367 14 207 0	367 14 009 0		
15		FA-64/N6											
16													
17		-64S/N6		367 20 002 0	467 21 002 0	-	067 22 602 4	367 12 020 4	134 / 150	367 14 207 0	367 14 009 0		
18		FA-64S/N6											
19													
20													
21	⊙	-64/N6				367 22 055 3							Kante rechts Right hand edge
22	⊙	FA-64/N6											min. 2,5 mm
23													
24	⊙	-64/N6				367 22 061 3							Kante links Left hand edge
25	⊙	FA-64/N6											min. 2,5 mm
26													
27													
28													
29													
30		-64/N9		367 20 019 0	467 21 002 0	367 22 047 4		367 12 020 4	134 / 150	367 14 207 0	367 14 009 0		
31		FA-64/N9											
32													
33													
34	⊙	-64/N9				367 22 059 3							Kante rechts Right hand edge
35	⊙	FA-64/N9											min. 2,5 mm
36													
37	⊙	-64/N9				367 22 062 3							Kante links Left hand edge
38	⊙	FA-64/N9											min. 2,5 mm
39													
40													
41													
42													
43	⊙	-63/N6				367 22 083 4						a = 3 mm	
44	⊙	FA-63/N6				367 22 084 4						a = 4 mm	
45	⊙	-64/N6				367 22 085 4						a = 5 mm	
46	⊙	FA-64/N6				367 22 086 4						a = 6 mm	
47													
48													
49													
50													
51	⊙	-63/N6											
52	⊙	FA-63/N6											
53	⊙	-64/N6				367 22 102 4						a = 5 mm	
54	⊙	FA-64/N6				367 22 103 4						a = 6 mm	
55													
56													
57													
58													
59													
60													
61		63 / N6				376 22 148 4							Absteppbr. Stitching Marg. left hand
62													16 mm
63													
64													
65													
66													
67													
68													
69													
70													
71													
72													
73													
74													
75													
76													
77													
78													
79													
80													
81													
82													
83													
84													
85													
86													
87													
88													
89													
90													
91													

KH.4.79 ⊙ Teil auf Wunsch für bestimmte Einsatzzwecke ● Garnitur auf Wunsch für bestimmte Einsatzzwecke, wobei Einzelteile auch in der Grundklasse sein können. ▲ Einzelteile siehe Blatt ①  
 JT.985 ▶ TV - Teil nur als Ersatz lieferbar  
 KH8.89

A	B	C	D	E	F	G	H	J	K	L	M	N	O
Einnadel mit Nadeltransport Single needle with needle feed												Gruppe: Nr. <b>B.2</b> Group:	
E-Nr.:	<b>467</b>												
1													
2													
3													
4													
5		<del>VA-62/N4,5-6</del>	4	367 20 017 4	367 21 015 0	367 22 025 4		367 12 022 4	134 / 100	367 14 008 0	-	367 33 017 0	
6		<del>VF-62/N4,5-6</del>											
7													
8													
9													
10													
11	●	<del>VA-62/N4,5-6</del>	6	367 20 024 4	367 21 015 0	367 22 052 4		367 12 023 4	134 / 100	367 14 008 0	-	367 33 017 0	
12	●	<del>VF-62/N4,5-6</del>											
13													
14													
15													
16													
17													
18													
19													
20													
21													
22													
23													
24													
25													
26													
27													
28													
29													
30													
31													
32													
33													
34													
35													
36													
37													
38													
39													
40													
41													
42													
43													
44													
45													
46													
47													
48													
49													
50													
51													
52													
53													
54													
55													
56													
57		<del>V5-62/N4,5</del>	8/4	367 20 028 4	367 21 019 0	367 22 058 4		367 12 023 4	134 / 100	367 14 020 0	-	367 33 096 0	
58		<del>V5F-62/N4,5</del>											
59													
60													
61													
62													
63	●	<del>V5-62/N4,5</del>	6,5/3,5	367 20 027 4	367 21 019 0	367 22 057 4		367 12 023 4	134 / 100	367 14 020 0	-	367 33 095 0	
64	●	<del>V5F-62/N4,5</del>											
65													
66													
67													
68													
69		V5F2-62/N4,5	6,5/3,5	467 20 011 4	367 21 019 0	467 22 022 4		367 12 020 4	134 / 100	367 14 020 0		467 33 012 0	Federfuß
70													
71													
72													
73													
74		V5F2-62/N4,5	8/4	467 20 012 4	367 21 019 0	467 22 023 4		367 12 020 4	134 / 100	367 14 020 0		467 33 013 0	Federfuß
75													
76													
77													
78													
79													
80													
81													
82													
83													
84													
85													
86													
87													
88													
89													
90													
91													

Messer siehe: " Ersatzteilliste Nähmaschine, Blatt 10 "  
Knives see: " Spare Part List Sewing Machine, page 10 "

KH.7.80 ● Teil auf Wunsch für bestimmte Einsatzzwecke ● Garnitur auf Wunsch für bestimmte Einsatzzwecke, wobei Einzelteile auch in der Grundklasse sein können. ▲ Einzelteile siehe Blatt ①  
JT.9.85 ▼ TV-Teil nur als Ersatz lieferbar  
KH.8.85

A	B	C	D	E	F	G	H	J	K	L	M	N	O
Einnadel mit Nadeltransport Single needle with needle feed												Gruppe: N r. C.0 Group:	
E-Nr.:	467												
1													Transporteur-
2													breite
3													
4													
5		-72/N4,5		367 20 035 0	367 21 003 0	367 22 020 3	367 22 098 3	367 12 020 4	134/100	367 14 008 0	367 14 009 0	367 22 152 3	6 mm
6		FA-72/N4,5											
7													
8		-372/N4,5		367 20 035 0	367 21 003 0	367 22 020 3	367 22 098 3	367 12 020 4	134-35/100	367 14 008 0	367 14 009 0	367 22 152 3	6 mm
9		FA-372/N4,5											
10													
11													
12		-73-G2/N6							134 / 120				
13		FA-73-G2/N6							134-35/120				
14	K467 E12	-73/N6		367 20 003 0	467 21 004 0	367 22 020 3	367 22 098 3	367 12 020 4	134 / 120	367 14 008 0	367 14 009 0	367 22 152 3	6 mm
15		FA-73/N6											
16													
17													
18		-73H12/N6		367 20 003 0	467 21 004 0	367 22 020 3	367 22 098 3	367 12 020 4	134-35/120	367 14 008 0	367 14 009 0	367 22 152 3	6 mm
19		FA-73H12/N6											
20													
21													
22		-373/N6		467 20 009 0	467 21 006 0	467 22 001 3	367 22 099 3	367 12 020 4	134-35/120	367 14 207 0	367 14 009 0	467 22 037 3	8 mm
23		FA-373/N6		467 20 009 0	467 21 007 0	467 22 001 3	367 22 099 3	367 12 020 4	134-35/120	367 14 207 0	367 14 009 0	467 22 037 3	8 mm
24				467 20 001 0									
25		-373/N6			467 90 013 3								
26		FA-373/N6		467 20 009 0	467 21 007 0	367 22 155 3	367 22 154 3	367 12 020 4	134-35/120	367 14 207 0	367 14 009 0		
27													
28		-74/N6		467 20 001 0	467 21 001 0	467 22 001 3	367 22 099 3	367 12 020 4	134 / 150	367 14 207 0	367 14 009 0	467 22 002 3	8 mm
29		-74 H12/N6							134-35/150				
30		-374/N6							134-35/150				
31				467 20 00900									
32													
33		FA-74/N6		467 20 001 0	467 21 013 0	467 22 001 3	367 22 099 3	367 12 020 4	134 / 150	367 14 207 0	367 14 009 0		
34		FA-74/G2											
35	K767 E8	FA-74H12/N6											
36		FA-374/N6											
37		FA-374-G2											
38													
39													
40													
41	●	-73		367 20 003 0	467 21 004 0	367 22 020 3	367 22 142 3	367 12 020 4	134 / 120	367 14 008 0	367 14 009 0		
42	●	-73/N9		367 20 020 0	467 21 004 0	367 22 020 3	367 22 142 3	367 12 020 4	134 / 120	367 14 008 0	367 14 009 0		
43	●	-373		367 20 003 0	467 21 004 0	367 22 020 3	367 22 142 3	367 12 020 4	134-35/120	367 14 008 0	367 14 009 0		
44	●	FA-373		367 20 003 0	467 21 004 0	367 22 020 3	367 22 142 3	367 12 020 4	134-35/120	367 14 008 0	367 14 009 0		
45		-73/N 12		467 20 018 0	467 21 004 0	367 22 020 3	367 22 142 3	367 12 020 4	134 / 120	367 14 207 0	367 14 009 0		
46													
47													
48													
49													
50		-373/N9		467 20 002 0	467 21 006 0	467 22 037 3	467 22 002 3	367 12 020 4	134-35/120	367 14 207 0	367 14 009 0	467 22 004 3	8 mm
51		FA-373/N9		467 20 002 0	467 21 007 0	467 22 037 3	467 22 002 3	367 12 020 4	134-35/120	367 14 207 0	367 14 009 0	467 22 004 3	8 mm
52		373/N9		467 20 002 0	467 21 006 0	467 22 037 3	467 22 014 3	367 12 020 4	134-35/120	367 14 207 0	367 14 009 0		
53													
54													
55													
56													
57													
58		-374/N9		467 20 002 0	467 21 001 0	467 22 001 3	467 22 004 3	367 12 020 4	134-35/150	367 14 207 0	367 14 009 0	467 22 002 3	8 mm
59		FA-374/N9											
60		FA-375/N9		467 20 026 0	467 21 013 0	467 22 042 3	467 22 004 3	367 12 020 4	134-35/150	367 14 207 0	367 14 009 0	467 22 002 3	8 mm
61													
62													
63													
64													
65													
66													
67													
68													
69		-373/N6		467 20 009 0	467 21 006 0	367 22 021 3	367 22 022 3	367 12 020 4	134-35/120	367 14 008 0	367 14 009 0	367 24 033 4	Anschlag Doppelkeder Doubleplepiping
70		FA-373/N6		467 20 009 0	467 21 007 0	367 22 021 3	367 22 022 3	367 12 020 4	134-35/120	367 14 008 0	367 14 009 0	367 24 033 4	
71													
72													
73													
74		-72/N4,5,6							134/100				speziell VW
75		FA-72/N4,5,6							134/100				Kante rechts Right hand edge
76		-372/N4,5,6				067 22 071 3	367 22 026 3						
77		FA-372/N4,5,6											
78		-73/N6		367 20 003 0	467 21 004 0				134 / 120				
79		FA-73/N6		367 20 003 0	467 21 004 0				134 / 120				min. 1 mm
80		-373/N6		467 20 009 0	467 21 006 0				134-35/120				Kante links Left hand edge
81		FA-373/N6		467 20 009 0	467 21 007 0				134-35/120				
82		-74/N6		467 20 001 0	467 21 001 0	067 22 070 3	367 22 034 3		134 / 150				
83		FA-74/N6		467 20 001 0	467 21 013 0				134 / 150				
84		-374/N6		467 20 001 0	467 21 001 0				134-35/150				min. 1 mm
85		FA-374/N6		467 20 001 0	467 21 014 0				134-35/150				
86		FA-74/N6		467 90 001 2	467 90 001 3	067 22 068 3	467 90 001 5	367 12 020 4	134 / 150	367 14 207 0	367 14 009 0		Keder Ø5
87		FA-74/N9		467 20 019 0	467 90 001 3	067 22 068 3		367 12 020 4	134 / 150	367 14 207 0	367 14 009 0		
88													
89		FA-373-G2		467 20 020 0	467 21 009 0	467 22 037 3	467 22 039 3	367 12 020 4	134-35/120	367 14 207 0	367 14 009 0		Keder Ø6
90													
91													

KH.1181 ● Teil auf Wunsch für bestimmte Einsatzzwecke ● Garnitur auf Wunsch für bestimmte Einsatzzwecke, wobei Einzelteile auch in der Grundklasse sein können. ▲ Einzelteile siehe Blatt 1  
 JT985 ▲ TV - Teil nur als Ersatz lieferbar  
 KH.789,190













A	B	C	D	E	F	G	H	J	K	L	M	N	O		
Einnadel mit kombiniertem Ober-, Unter- und Nadeltransport Single needle with unison feed												Gruppe: Nr. <b>C.2</b> Group:			
	E Nr.: <b>467</b>														
1															
2		LG-73-G2/N6													
3	K467 E5	LG-73/N6	-	367 20 029 0	367 21 020 0	067 22 099 3	367 22 010 3	367 12 020 4	134-35/120	367 14 032 0		367 14 017 0			
4		LGF-73/N6													
5															
6		LG-73H12/N6	-	367 20 029 0	367 21 020 0	067 22 099 3	367 22 010 3	367 12 020 4	134-35/120	367 14 032 0		367 14 017 0			
7		LGF-73H12/N6													
8															
9															
10		LG-73/N9	-	367 20 030 0	367 21 020 0	067 22 099 3	367 22 049 3	367 12 020 4	134-35/120	367 14 032 0		367 14 017 0			
11		LG-73/N6													
12	K467 E14	LGF-73/6	-	367 20 046 0	367 21 020 0	067 22 100 3	367 22 010 3	367 12 020 4	134-35/120	367 14 032 0		367 14 017 0			
13		LGE-73-G2													
14		LG-74/N6	-	367 20 029 0	467 21 005 0	367 22 074 3	367 22 010 3	367 12 023 4	134-35/150	367 14 032 0		367 14 017 0			
15	K467 E6	LG-74/N9	-	367 20 030 0	467 21 005 0	367 22 074 3	367 22 049 3	367 12 023 4	134-35/150	367 14 032 0		367 14 017 0			
16															
17															
18															
19															
20															
21															
22								367 22 151 3							
23	K467 E15	AE-73 / N6	11,5	367 20 033 0	367 21 021 3	167 22 015 3	367 90 010 2	367 12 020 4	134-35/120	367 14 019 0	Reißverschluss	367 24 042 3	367 33 079 0		
24	K467 E7	AE-73 / N6	11,5	367 20 033 0	367 21 021 3	167 22 015 3	367 22 093 3	367 12 020 4	134-35/120	367 14 019 0		367 24 042 3	367 33 079 0		
25		AE-73 / N9	11,5	367 90 006 1	367 21 021 3	167 22 015 3	367 90 006 2	367 12 020 4	134-35/120	367 14 019 0		367 24 042 3	367 33 079 0		
26	K467 E8	AE-73 / N6	13,5	367 20 033 0	367 90 007 1	367 90 006 9	367 22 093 3	367 12 020 4	134-35/120	367 14 019 0		367 24 042 3	367 33 079 0		
27	K467 E9	AE-73 / N6	8,7	367 20 033 0	367 90 012 0	367 90 012 1	367 22 093 3	367 12 020 4	134-35/120	367 14 019 0		367 24 042 3	367 33 173 0		
28		AE-73 N9	10,5	367 90 006 1	367 90 007 2	167 22 015 3	367 90 006 2	367 12 020 4	134-35/120	367 14 019 0		367 24 042 3	367 33 173 0		
29		AE-73 N6	10,5	367 20 033 0	367 90 007 2	167 22 015 3	367 90 006 2	367 12 020 4	134-35/120	367 14 019 0		367 24 042 3	367 33 173 0		
30															
31															
32															
33															
34					mit kleinem Stichloch							Kletterfuß			
35					367 21 006 0										
36		LG-73/N6	-	367 20 006 0	367 21 007 0	367 22 020 3	367 22 098 3	367 12 020 4	134-35/120	367 14 032 0		367 22 004 3	367 33 168 0		
37															
38															
39		LG-73/N9	-	367 20 007 0	367 21 007 0	367 22 020 3	367 22 098 3	367 12 020 4	134-35/120	367 14 032 0		367 22 004 3	367 33 168 0		
40															
41															
42															
43															
44															
45															
46															
47															
48															
49		VA-73/N6	4	367 20 011 4	367 21 012 0	367 22 101 3	367 22 017 3	367 12 022 4	134/120	367 14 032 0		367 14 012 0	367 33 145 0		
50		VF-73/N6													
51															
52															
53		VA-73/N6	5	367 20 043 4	367 21 030 0	367 22 128 3	367 22 015 3	367 12 020 4	134/120	367 14 032 0		367 14 012 0	367 33 145 0		
54		VF-73/N6													
55		VA-374/N6	5	367 20 043 4	367 21 031 0	367 22 128 3	367 22 015 3	367 12 020 4	134-35/150	367 14 032 0		367 14 012 0	367 33 145 0		
56		VF-374/N6													
57		VA(VF)-373/N6	4	367 20 049 0	367 21 035 0	367 22 101 3	367 22 017 3	367 12 022 4	134/120	367 14 032 0		367 14 030 0	367 33 145 0		
58		VA(VF)-373/N6	6	367 20 050 0	367 21 036 0	067 22 153 3	367 22 015 3	367 12 020 4	134/120	367 14 032 0		367 14 031 0	367 33 145 0		
59		VA(VF)-373/N6	6	367 20 048 0	367 21 033 0	067 22 138 3	367 22 019 3	367 12 020 4	134/120	367 14 032 0		367 14 028 0	367 33 145 0		
60															
61		VK-72/N6	2,5	367 20 010 4	367 21 011 0	067 22 049 3	367 22 018 3	367 12 024 4	134/100	367 14 032 0		367 14 012 0	367 33 017 0		
62		VKF-72/N6													
63		VA(VF) 373 / N6	3,0	367 20 052 4	367 21 031 0	367 22 153 3	367 22 018 3	367 12 024 4	134/120	367 14 032 0		367 14 012 0	367 33 017 0		
64															
65															
66															
67		VA-73/N6	6	367 20 009 4	367 21 009 0	067 22 153 3	367 22 015 3	367 12 020 4	134/120	367 14 032 0		367 14 012 0	367 33 145 0		
68		VF-73/N6													
69															
70															
71		VA-73/N9	8	367 20 044 4	367 21 013 0	067 22 138 3	367 22 140 3	367 12 020 4	134/120	367 14 032 0		367 14 012 0	367 33 145 0		
72		VA-373/N6	8	367 20 048 0	367 21 033 0	067 22 138 3	367 22 019 3	367 12 020 4	134/120	367 14 032 0		367 14 028 0	367 33 145 0		
73		VA-73/N6	8	367 20 012 4	367 21 013 0	067 22 138 3	367 22 019 3	367 12 020 4	134/120	367 14 032 0		367 14 012 0	367 33 145 0		
74		VF-73/N6													
75															
76		VF-74/N6	10	367 20 037 4	367 21 027 0	467 22 001 3	367 22 113 3	367 12 020 4	134-35/150	367 14 032 0		367 14 023 0	367 33 145 0		
77		VF-73/N6	10	367 20 038 4	367 21 028 0	367 22 114 3	367 22 115 3	367 12 020 4	134/120	367 14 032 0		367 14 023 0	367 33 145 0		
78		VA-73/N6	12	367 20 040 4	367 21 029 0	367 22 125 3	367 22 126 3	367 12 020 4	134/120	367 14 032 0		367 14 012 0	367 90 012 8		
79		VF-73/N6													
80		VF-73/N6	15	367 90 012 2	367 90 012 5	367 90 012 6	367 90 012 7	367 12 020 4	134/120	367 14 032 0		367 14 023 0	367 90 012 8		
81															
82		VA u. VF-73/N6	-			067 22 054 3	367 22 087 3		134/120						
83		VA u. VF-73/N6	-			067 22 055 3	367 22 088 3		134/120						
84		VA u. VF-73/N6	-			067 22 056 3	367 22 089 3		134/120						
85		VA u. VF-73/N6	-			067 22 057 3	367 22 090 3		134/120						
86		VA u. VF-73/N6	-			067 22 173 3	367 22 091 3		134/120						
87		VA u. VF-73/N6	-			067 22 172 3	367 22 092 3		134/120						
88															
89															
90															
91															



① Teil auf Wunsch für bestimmte Einsatzzwecke

● Gamitur auf Wunsch für bestimmte Einsatzzwecke, wobei Einzelteile auch in der Grundklasse sein können.





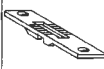

▲ Einzelteile siehe Blätt ①





A	B	C	D	E	F	G	H	J	K	L	M	N	O
Zweinadel feststehend Fixed twin needle												Gruppe: Nr. <b>D.0</b> Group:	
E-Nr.:	<b>467</b>	NA											
1													
2		<del>2025/N4,5;6</del>	0,8	367 20 201 0	367 21 201 0	067 22 601 4	268 22 202 3	367 23 206 4	134Lr/100	367 14 213 0	367 14 214 0		
3		FA-2025/N4,5;6											
4													
5													
6													
7		<del>2025/N4,5;6</del>	1,2	367 20 209 0	367 21 201 0	067 22 601 4	268 22 202 3	367 23 206 4	134Lr/100	367 14 213 0	367 14 214 0		
8		FA-2025/N4,5;6											
9		<del>2035/N4,5;6</del>	1,2	367 20 206 0	367 21 206 0	067 22 602 4	268 22 203 3	367 23 207 4	134Lr/130	367 14 213 0	367 14 214 0	●	
10		FA-2035/N4,5;6											
11													
12													
13													
14		<del>2025/N4,5;6</del>	1,6	367 20 244 0	367 21 206 0	067 22 601 4	268 22 202 3	367 23 206 4	134Lr/100	367 14 213 0	367 14 214 0		
15		FA-2025/N4,5;6											
16		<del>2035/N6;4,5</del>	1,6	367 20 227 0	367 21 206 0	067 22 602 4	268 22 203 3	367 23 207 4	134Lr/130	367 14 213 0	367 14 214 0	●	
17		FA-2035/N6;4,5											
18													
19													
20													
21													
22													
23		<del>2035/N6;4,5</del>	2,0	367 20 218 0	367 21 211 0	067 22 602 4	268 22 203 3	367 23 207 4	134Lr/130	367 14 213 0	367 14 214 0	●	
24		FA-2035/N6;4,5											
25													
26													
27													
28													
29													
30													
31													
32		<del>2035/N6;4,5</del>	2,4	367 20 211 0	367 21 211 0	067 22 602 4	268 22 203 3	367 23 207 4	134Lr/130	367 14 213 0	367 14 214 0		
33		FA-2035/N6;4,5											
34		<del>2045/N6;4,5</del>	2,4	467 20 203 0	367 21 211 0	067 22 602 4	268 22 204 3	367 23 208 4	134Lr/160	367 14 213 0	367 14 214 0		
35		FA-2045/N6;4,5											
36													
37													
38													
39													
40													
41		<del>2035/N6;4,5</del>	2,8										
42		FA-2035/N6;4,5	2,8										
43		<del>2045/N6;4,5</del>											
44		FA-2045/N6;4,5											
45													
46													
47													
48													
49													
50		<del>2035/N6;4,5</del>	3,2	367 20 220 0	367 21 218 0	067 22 602 4	268 22 204 3	367 23 208 4	134Lr/130	367 14 213 0	367 14 214 0		
51		FA-2035/N6;4,5											
52		<del>2045/N6;4,5</del>	3,2	467 20 201 0	367 21 218 0	067 22 602 4	268 22 204 3	367 23 208 4	134Lr/160	367 14 213 0	367 14 214 0		
53		FA-2045/N6;4,5											
54													
55		<del>2045/N6</del>	3,2	467 20 211 0	467 21 210 0	067 22 602 4	268 22 204 3	367 23 223 4	134Lr/160	367 14 213 0	367 14 214 3	●	Nadelstärke 230 für starke Garne
56		FA-2045/N6											
57													
58													
59													
60													
61													
62													
63													
64													
65													
66													
67													
68													
69													
70													
71													
72													
73													
74													
75													
76													
77													
78													
79													
80													
81													
82													
83													
84													
85													
86													
87													
88													
89													
90													
91													







KH.1181 ● Teil auf Wunsch für bestimmte Einsatzzwecke ● Garnitur auf Wunsch für bestimmte Einsatzzwecke, wobei Einzelteile auch in der Grundklasse sein können. ▲ Einzelteile siehe Blatt ①  
 7.89 ▲ TV-Teil nur als Ersatz lieferbar  
 KH.8.89



A	B	C	D	E	F	G	H	J	K	L	M	N	O
Zweinadel mit Nadeltransport Twin needle with needle feed												Gruppe: Nr. <b>E.0</b> Group:	
E-Nr.:	<b>467</b>	NA											
1													
2													
3													
4													
5													
6													
7		-262/N4, 5; 6	3	367 20 238 0	367 21 234 0	367 22 248 4		367 23 210 4	134 cf	367 14 213 0	367 14 214 0		
8		FA-262/N4, 5; 6											
9		-263/N6	3	367 20 238 0	367 21 235 0	367 22 248 4		367 23 210 4	134	367 14 213 0	367 14 214 0		
10		FA-263/N6											
11													
12													
13													
14													
15													
16													
17													
18													
19													
20													
21													
22													
23		-262/N4, 5; 6	4	367 20 239 0	367 21 236 0	367 22 249 4		367 23 211 4	134 cf	367 14 207 0	367 14 208 0		
24		FA-262/N4, 5; 6											
25		-263/N6	4	367 20 239 0	367 21 237 0	367 22 249 4		367 23 211 4	134	367 14 207 0	367 14 208 0		
26		FA-263/N6											
27		-264/N6	4	367 20 239 0	367 21 205 0	367 22 249 4		367 23 211 4		367 14 207 u	367 14 208 0		
28		FA-264/N6											
29													
30													
31													
32													
33													
34													
35													
36													
37													
38													
39													
40		-262/N4, 5; 6	5	367 20 222 0	367 21 220 0	367 22 219 4		367 23 212 4	134 cf	367 14 207 0	367 14 208 0		
41		FA-262/N4, 5; 6											
42		-263/N6	5	367 20 222 0	367 21 221 0	367 22 219 4		367 23 212 4	134	367 14 207 0	367 14 208 0		
43		FA-263/N6											
44		-264/N6	5	367 20 222 0	367 21 201 0	367 22 219 4		367 23 212 4	134	367 14 207 0	367 14 208 0		
45		FA-264/N6											
46		-263/N9	5	367 20 223 0	367 21 221 0	367 22 220 4		367 23 212 4	134	367 14 207 0	367 14 208 0		
47		FA-263/N9											
48		-264/N9	5	367 20 223 0	367 21 201 0	367 22 220 4		367 23 212 4	134	367 14 207 0	367 14 208 0		
49		FA-264/N9											
50		-262 / N6	5	367 20 255 0	367 21 261 0	367 22 220 4		367 23 212 4	134	367 14 207 0	367 14 208 0	m. Mittfestig z. Kappen	
51													
52													
53													
54													
55		-262/N4, 5; 6	6	367 20 219 0	367 21 217 0	367 22 217 4		367 23 209 4	134 cf	367 14 207 0	367 14 208 0		
56		FA-262/N4, 5; 6											
57		-263/N6	6	367 20 219 0	367 21 216 0	367 22 217 4		367 23 209 4	134	367 14 207 0	367 14 208 0		
58		FA-263/N6											
59		-264/N6	6	367 20 219 0	367 21 202 0	367 22 217 4		367 23 209 4	134	367 14 207 0	367 14 208 0		
60		FA-264/N6											
61		-263/N9	6	367 20 224 0	367 21 216 0	367 22 221 4		367 23 209 4	134	367 14 207 0	367 14 208 0		
62		FA-263/N9											
63		-264/N9	6	367 20 224 0	367 21 202 0	367 22 221 4		367 23 209 4	134	367 14 207 0	367 14 208 0		
64		FA-264/N9			367 21 202 0								
65													
66	⊙	-262N 4, 5; 6	6	367 20 219 0	367 21 217 0	367 22 281 4		367 23 209 4	134	367 14 207 0	367 14 208 0	federnder Anschlag	
67	⊙	FA-262N 4, 5; 6										spring loading stop	
68													
69													
70													
71		-262/N4, 5; 6	8	367 20 207 0	367 21 209 0	367 22 212 4		367 23 204 4	134 cf	367 14 201 0	367 14 202 0		
72		FA-262/N4, 5; 6											
73		-263/N6	8	367 20 207 0	367 21 207 0	367 22 212 4		367 23 204 4	134	367 14 201 0	367 14 202 0		
74		FA-263/N6											
75		-264/N6	8	367 20 207 0	367 21 203 0	367 22 212 4		367 23 204 4	134	367 14 201 0	367 14 202 0		
76		FA-264/N6											
77		-263/N9	8	367 20 225 0	367 21 207 0	367 22 222 4		367 23 204 4	134	367 14 201 0	367 14 202 0		
78		FA-263/N9											
79		-264/N9	8	367 20 225 0	367 21 203 0	367 22 222 4		367 23 204 4	134	367 14 201 0	367 14 202 0		
80		FA-264/N9											
81													
82													
83													
84													
85													
86													
87													
88													
89													
90													
91													

KH.11.81 ⊙ Teil auf Wunsch für bestimmte Einsatzzwecke ● Garnitur auf Wunsch für bestimmte Einsatzzwecke, wobei Einzelteile auch in der Grundklasse sein können. ▲ Einzelteile siehe Blatt ①  
7.89 ▶ TV - Teil nur als Ersatz lieferbar

A	B	C	D	E	F	G	H	J	K	L	M	N	O
Zweinadel mit Nadeltransport Twin needle with needle feed												Gruppe: Nr. <b>E.1</b> Groupe:	
E-Nr.:	<b>467</b>	NA											
1		-262/N4,5; 6	10	367 20 204 0	367 21 204 0	367 22 204 4		367 23 202 4	134/100	367 14 201 0	367 14 202 0		
2		FA-262/N4,5; 6											
3		-263/N6	10	367 20 204 0	367 21 205 0	367 22 204 4		367 23 202 4	134/120	367 14 201 0	367 14 202 0		
4		FA-263/N6											
5		-264/N6	10	367 20 204 0	467 21 204 0	367 22 204 4		367 23 202 4	134/150	367 14 201 0	367 14 202 0		
6		FA-264/N6											
7		-263/N9	10	367 20 205 0	367 21 205 0	367 22 223 4		367 23 202 4	134/120	367 14 201 0	367 14 202 0		
8		FA-263/N9											
9		-264/N9	10	367 20 205 0	467 21 204 0	367 22 223 4		367 23 202 4	134/150	367 14 201 0	367 14 202 0		
10		FA-264/N9											
11		263/N12	10	367 20 240 0	367 21 205 0	367 22 207 4		367 23 202 4	134/120	367 14 201 0	367 14 202 0		
12													
13													
14													
15													
16													
17		-262/N4,5; 6	12	367 20 208 0	367 21 208 0	367 22 213 4		367 23 205 4	134/100	367 14 205 0	367 14 206 0		
18		FA-262/N4,5; 6											
19		-263/N6	12	367 20 208 0	367 21 223 0	367 22 213 4		367 23 205 4	134/120	367 14 205 0	367 14 206 0		
20		FA-263/N6											
21													
22													
23													
24													
25													
26													
27													
28													
29													
30													
31													
32													
33		-262/N4,5; 6	14										
34		FA-262/N4,5; 6	14	367 20 228 0	367 21 224 0	367 22 341 4		367 23 215 4	134/100	367 14 205 0	367 14 206 0		Ausgleichfuß für Reißverschluss Equalising foot for Zipfastners
35		-263/N6	14	367 20 228 0	367 21 224 0	367 22 335 4		367 23 215 4	134/120	367 14 205 0	367 14 206 0		
36		FA-263/N6											
37													
38													
39													
40													
41													
42													
43													
44													
45													
46													
47													
48													
49		-262/N4,5; 6	16	367 20 229 0	367 21 248 0	367 22 283 4		367 23 216 4	134/100	367 14 221 0	367 14 222 0		
50		FA-262/N4,5; 6											
51		-263/N6	16	367 20 229 0	367 21 225 0	367 22 283 4		367 23 216 4	134/120	367 14 221 0	367 14 222 0		
52		FA-263/N6											
53		-264	16	367 20 229 0	367 21 260 0	367 22 283 4		367 23 216 4	134/150	367 14 221 0	367 14 222 0		
54													
55													
56													
57													
58													
59													
60													
61		-262/N4,5; 6	20	367 20 242 0	367 21 241 0	367 22 294 4		367 23 218 4	134/100	367 14 219 0	367 14 220 0		
62		FA-262 N4,5											
63		263/N6	20	367 20 242 0	367 21 239 0	367 22 294 4		367 23 218 4	134/120	367 14 219 0	367 14 220 0		
64		FA 263/N6											
65													
66		-262/N4,5; 6	22	367 20 226 0	367 21 222 0	367 22 228 4		367 23 214 4	134/100	367 14 219 0	367 14 220 0		
67		FA-262/N4,5; 6											
68													
69													
70													
71													
72													
73													
74													
75													
76													
77													
78													
79													
80													
81													
82													
83		-262N 4,5; 6	24										
84													
85													
86													
87													
88													
89													
90													
91													

KH.11.81  Teil auf Wunsch für bestimmte Einsatzzwecke  Garnitur auf Wunsch für bestimmte Einsatzzwecke, wobei Einzelteile auch in der Grundklasse sein können.  Einzelteile siehe Blatt   
 J.T.985  TV-Teil nur als Ersatz lieferbar  
 KH.7.89







A	B	C	D	E	F	G	H	J	K	L	M	N	O
												Gruppe: Nr. <b>E2</b>	
	E-Nr.: <b>467BN</b>												
1	<del>262/N4,5,6</del>	26	367 20 243 0	367 21 244 0	367 22 288 4			367 23 221 4	134/100	367 14 223 0	367 14 224 0		
2	FA=262/N4,5,6	26											
3	<del>263/N+6</del>	26											
4	FA=263/N+6	26											
5	<del>264/N+6</del>	26	367 20 243 0	467 21 220 0	367 22 288 4			367 23 221 4	134/150	367 14 223 0	367 14 224 0		
6	262 /N12	26	367 20 254 0	367 21 244 0	367 22 336 4			367 23 221 4	134/100	367 14 223 0	367 14 224 0		
7													
8													
9													
10													
11													
12													
13													
14													
15													
16			28										
17			28										
18			28										
19			28										
20			28										
21			28										
22													
23													
24													
25													
26													
27													
28													
29													
30													
31													
32			30										
33			30										
34			30										
35			30										
36			30										
37			30										
38													
39													
40													
41													
42													
43													
44													
45													
46													
47													
48			32										
49			32										
50			32										
51			32										
52			32										
53			32										
54													
55													
56													
57													
58													
59													
60													
61													
62		263/N6	34	367 20 250 0	367 21 255 0	367 22 323 4		367 23 235 4	134/120	367 14 217 0	367 14 218 0		
63													
64													
65													
66													
67													
68													
69													
70													
71													
72													
73													
74													
75													
76													
77													
78													
79													
80													
81													
82													
83													
84													
85													
86													
87													
88													
89													
90													
91													

KH.1181  Teil auf Wunsch für bestimmte Einsatzzwecke ● Garnitur auf Wunsch für bestimmte Einsatzzwecke, wobei Einzelteile auch in der Grundklasse sein können. ▲ Einzelteile siehe Blatt ①  
 JT.985  TV-Teil nur als Ersatz lieferbar











A	B	C	D	E	F	G	H	J	K	L	M	N	O
E-Nr.: <b>467BN</b>		NA											
1													
2													
3													
4													
5													
6		<del>263/N42</del>	40	367 20 245 0	367 21 246 0	367 22 269 4		367 23 224 4	134/120	367 14 227 0	367 14 228 0		
7													
8													
9													
10													
11													
12													
13													
14													
15		<del>263/N4, 5, 6</del>	44	367 20 246 0	367 21 247 0	367 22 275 4		367 23 226 4	134/100	367 14 231 0	367 14 232 0		
16		263/N6	44	367 20 246 0	367 21 259 0	367 22 275 4		367 23 226 4	134/120	367 14 231 0	367 14 232 0		
17													
18													
19													
20													
21													
22													
23													
24													
25													
26													
27													
28													
29													
30													
31													
32													
33													
34													
35													
36													
37													
38													
39													
40													
41													
42													
43													
44													
45													
46													
47													
48													
49													
50													
51													
52													
53													
54													
55													
56													
57													
58													
59													
60													
61													
62													
63													
64													
65													
66													
67													
68													
69													
70													
71													
72													
73													
74													
75													
76													
77													
78													
79													
80													
81													
82													
83													
84													
85													
86													
87													
88													
89													
90													
91													

KH1,81 ① Teil auf Wunsch für bestimmte Einsatzzwecke ● Garnitur auf Wunsch für bestimmte Einsatzzwecke, wobei Einzelteile auch in der Grundklasse sein können. ▲ Einzelteile siehe Blatt ①  
 JT.9.85  
 KH.8.89









A	B	C	D	E	F	G	H	J	K	L	M	N	O
Zweifel mit kombinierten Ober-, Unter- und Nadeltransport Twin needle with unison feed												Gruppe: Nr. <b>F.0</b> Group:	
E-Nr.:	<b>467</b>	NA											
1		-272/N4,5; 6	3	367 20 238 0	367 21 234 0	067 22 231 3	367 22 299 3	367 23 210 4	134/100	367 14 213 0	367 14 214 0		
2		FA-272/N4,5; 6											
3		-273/N6	3	367 20 238 0	367 21 235 0	067 22 231 3	367 22 299 3	367 23 210 4	134/120	367 14 213 0	367 14 214 0		
4		FA-273/N6											
5		FA-273-G2											
6		-273H12/N6											
7		FA-273H12/N6	3	367 20 238 0	367 21 235 0	067 22 231 3	367 22 299 3	367 23 210 4	134-35/120	367 14 213 0	367 14 214 0		
8													
9													
10													
11													
12													
13													
14													
15													
16		-272/N4,5,6											
17		FA-272/N4,5,6	4	367 20 239 0	367 21 236 0	067 22 232 3	367 22 247 3	367 23 211 4	134/100	367 14 207 0	367 14 208 0		
18		-273/N6											
19	K767 E21/4	-273/N6	4	467 20 212 0	467 21 211 0	067 22 232 3	367 22 247 3	367 23 211 4	134/120	367 14 207 0	367 14 208 0		
20		FA-273-G2											
21		-273H12/N6	4	467 20 212 0	467 21 211 0	067 22 232 3	367 22 247 3	367 23 211 4	134-35/120	367 14 207 0	367 14 208 0		
22		FA-273H12/N6											
23		FA-274/N6	4	467 20 212 0	467 21 251 0	067 22 232 3	367 22 247 3	367 23 211 4	134/150	367 14 207 0	367 14 208 0		
24													
25													
26													
27													
28													
29													
30													
31													
32													
33		-272/N4,5; 6	5	367 20 222 0	367 21 220 0	067 22 233 3	367 22 224 3	367 23 212 4	134/100	367 14 207 0	367 14 208 0		
34		FA-272/N4,5; 6											
35		-273/N6	5	467 20 224 0	467 21 221 0	067 22 233 3	367 22 224 3	367 23 212 4	134/120	367 14 207 0	367 14 208 0		
36		FA-273/N6											
37		-273H12/N6	5	467 20 224 0	467 21 221 0	067 22 233 3	367 22 224 3	367 23 212 4	134-35/120	367 14 207 0	367 14 208 0		
38		FA-273H12/N6											
39		-274/N6	5	367 20 222 0	467 21 201 0	067 22 233 3	367 22 224 3	367 23 212 4	134/150	367 14 207 0	367 14 208 0		
40		FA-274/N6											
41		-274H12/N6	5	367 20 222 0	467 21 201 0	067 22 233 3	367 22 224 3	367 23 212 4	134-35/120	367 14 207 0	367 14 208 0		
42		FA-274H12/N6											
43		-273/N9	5	367 20 223 0	367 21 221 0	067 22 233 3	367 22 267 3	367 23 212 4	134/120	367 14 207 0	367 14 208 0		
44		FA-273/N9											
45													
46													
47													
48		-272/N4,5,6											
49		FA-272/N4,5,6	4	367 20 219 0	367 21 217 0	067 22 234 3	367 22 209 3	367 23 209 4	134/100	367 14 207 0	367 14 208 0		
50		-273/N6											
51	K767 E21/6	FA-273/N6	6	467 20 204 0	467 21 206 0	067 22 234 3	367 22 209 3	367 23 209 4	134/120	367 14 207 0	367 14 208 0		
52		FA-273-G2											
53		-273H12/N6	6	467 20 204 0	467 21 206 0	067 22 234 3	367 22 209 3	367 23 209 4	134-35/120	367 14 207 0	367 14 208 0		
54		FA-273H12/N6											
55		-274/N6	6	367 20 219 0	467 21 202 0	067 22 234 3	367 22 209 3	367 23 209 4	134/150	367 14 207 0	367 14 208 0		
56		FA-274/N6											
57		-274H12/N6	6	367 20 219 0	467 21 202 0	067 22 234 3	367 22 209 3	367 23 209 4	134-35/150	367 14 207 0	367 14 208 0		
58		FA-274H12/N6											
59		FA-274/N9	6	367 20 219 0	467 21 245 0	067 22 234 3	367 22 337 3	367 23 209 4	134/150	367 14 207 0	367 14 208 0		
60		-275/N9	6	467 20 249 0	467 21 253 0	467 22 219 3	367 22 337 3	367 23 209 4	134/150	367 14 207 0	367 14 208 0		
61													
62													
63													
64		-272/N4,5,6											
65		FA-272/N4,5,6	8	367 20 207 0	367 21 209 0	067 22 235 3	367 22 210 3	367 23 204 4	134/100	367 14 201 0	367 14 202 0		
66		273/N6											
67	K767 E21/8	FA-273/N6	8	467 20 209 0	467 21 208 0	067 22 235 3	367 22 210 3	367 23 204 4	134/120	367 14 201 0	367 14 202 0		
68		FA-273-G2											
69		-273H12/N6	8	467 20 209 0	467 21 208 0	067 22 235 3	367 22 210 3	367 23 204 4	134-35/120	367 14 201 0	367 14 202 0		
70		FA-273H12/N6											
71		-274/N6	8	367 20 207 0	467 21 203 0	067 22 235 3	367 22 210 3	367 23 204 4	134/150	367 14 201 0	367 14 202 0		
72		FA-274/N6											
73		-274H12/N6	8	367 20 207 0	467 21 203 0	067 22 235 3	367 22 210 3	367 23 204 4	134-35/150	367 14 201 0	367 14 202 0		
74		FA-274H12/N6											
75													
76													
77		-273/N9	8	467 20 223 0	467 21 208 0	067 22 235 3	367 22 277 3	367 23 204 4	134/120	367 14 201 0	367 14 202 0		
78		FA-273/N9											
79													
80		-273/N12	8	467 20 226 0	467 21 208 0	067 22 235 3	367 22 292 3	367 23 204 4	134/120	367 14 201 0	367 14 202 0		
81		FA-273/N12											
82													
83													
84													
85													
86													
87													
88													
89													
90													
91													

K.H.181 Teil auf Wunsch für bestimmte Einsatzzwecke Garnitur auf Wunsch für bestimmte Einsatzzwecke, wobei Einzelteile auch in der Grundklasse sein können. Einzelteile siehe Blatt ①  
 JT.985 TV-Teil nur als Ersatz lieferbar  
 KH.789,190











A	B	C	D	E	F	G	H	J	K	L	M	N	O
Zweinadel mit kombinierten Ober-; Unter- und Nadeltransport Twin needle with unison feed												Gruppe: Nr. <b>F.1</b> Group:	
E-Nr.:	<b>467</b>	NA											
1		-272/N4, 5; 6	10	367 20 204 0	367 21 204 0	067 22 238 3	367 22 201 3	367 23 202 4	134/100	367 14 201 0	367 14 202 0		
2		FA-272 / N4, 5, 6											
3		-273/N6	10	467 20 216 0	467 21 214 0	067 22 238 3	367 22 201 3	367 23 202 4	134/120	367 14 201 0	367 14 202 0		
4		FA-273/N6											
5		-273H12/N6	10	467 20 216 0	467 21 214 0	067 22 238 3	367 22 201 3	367 23 202 4	134-35/120	367 14 201 0	367 14 202 0		
6		FA-273H12/N6											
7		-274/N6	10	367 20 204 0	467 21 204 0	067 22 238 3	367 22 201 3	367 23 202 4	134/150	367 14 201 0	367 14 202 0		
8		FA-274 / N6											
9		-274H12/N6											
10		-273/N12	10	467 20 222 0	467 21 214 0	067 22 238 3	367 22 252 3	367 23 202 4	134/120	367 14 201 0	367 14 202 0		
11		FA-273/N12											
12		-273/N9	10	467 20 249 0	467 21 214 0	067 22 238 3	367 22 343 3	367 23 202 4	134/120	367 14 201 0	367 14 202 0		
13													
14													
15													
16													
17													
18		-272/N4, 5; 6	12	367 20 208 0	367 21 208 0	067 22 239 3	367 22 231 3	367 23 205 4	134/100	367 14 205 0	367 14 206 0		
19		FA-272 / N4, 5, 6											
20		-273/N6	12	467 20 206 0	467 21 207 0	067 22 239 3	367 22 231 3	367 23 205 4	134/120	367 14 205 0	367 14 206 0		
21		FA-273 / N6											
22		-273H12/N6	12	467 20 206 0	467 21 207 0	067 22 239 3	367 22 231 3	367 23 205 4	134-35/120	367 14 205 0	367 14 206 0		
23		FA-273H12/N6											
24													
25													
26													
27		273/N12	12	467 20 236 0	467 21 207 0	067 22 239 3	367 22 322 3	367 23 205 4	134/120	367 14 205 0	367 14 206 0		
28													
29													
30													
31													
32													
33													
34													
35													
36		-273/N6	14	367 20 228 0	367 21 224 0	067 22 241 3	367 22 232 3	367 23 215 4	134/120	367 14 205 0	367 14 206 0		
37		FA-273 / N6											
38		-273H12/N6	14	367 20 228 0	367 21 224 0	067 22 241 3	367 22 232 3	367 23 215 4	134-35/120	367 14 205 0	367 14 206 0		
39		FA-273H12/N6											
40													
41		274 / N6	14	467 20 221 0	467 21 237 0	067 22 241 3	367 22 232 3	367 23 215 4	134/150	367 14 205 0	367 14 206 0		
42		N9	14				367 22 338 3						
43													
44													
45													
46													
47													
48		272 / N6	16	367 20 229 0	367 21 248 0	067 22 242 3	367 22 233 3	367 23 216 4	134/100	367 14 221 0	367 14 222 0		
49		FA-272 / N6											
50		-273/N6	16	467 20 210 0	467 21 209 0	067 22 242 3	367 22 233 3	367 23 216 4	134/120	367 14 221 0	367 14 222 0		
51		FA-273 / N6											
52		-273H12/N6	16	467 20 210 0	467 21 209 0	067 22 242 3	367 22 233 3	367 23 216 4	134-35/120	367 14 221 0	367 14 222 0		
53		FA-273H12/N6											
54													
55													
56													
57													
58													
59													
60													
61													
62													
63													
64		-272/N6	18	367 20 241 0	367 21 240 0	067 22 243 3	367 22 253 3	367 23 220 4	134/100	367 14 221 0	367 14 222 0		
65		FA-272 / N6											
66		-273/N6	18	467 20 219 0	467 21 217 0	067 22 243 3	367 22 253 3	367 23 220 4	134/120	367 14 221 0	367 14 222 0		
67		FA-273 / N6											
68		-273H12/N6	18	467 20 219 0	467 21 217 0	067 22 243 3	367 22 253 3	367 23 220 4	134-35/120	367 14 221 0	367 14 222 0		
69		FA-273H12/N6											
70		273 / N9	18	467 20 241 0	467 21 217 0	067 22 243 3	367 22 340 3	367 23 220 4	134/120	367 14 221 0	367 14 222 0		
71		274 / N6	18	467 20 219 0	467 21 238 0	067 22 243 3	367 22 253 3	367 23 220 4	134/150	367 14 221 0	367 14 222 0		
72		FA-274 / N6											
73													
74													
75													
76													
77													
78													
79													
80													
81													
82													
83													
84													
85													
86													
87													
88													
89													
90													
91													

KH 1181 ① Teil auf Wunsch für bestimmte Einsatzzwecke ● Garnitur auf Wunsch für bestimmte Einsatzzwecke, wobei Einzelteile auch in der Grundklasse sein können. ▲ Einzelteile siehe Blatt ①  
 JI.985 ▶ TV - Teil nur als Ersatz lieferbar  
 KH.789

A	B	C	D	E	F	G	H	J	K	L	M	N	O
Zweinadel mit kombinierten Ober-; Unter- und Nadeltransport Twin needle with unison feed												Gruppe: Nr. <b>F.2</b> Group:	
E-Nr.:	<b>467</b>	NA											
1	-272/N6	20	367 20 242 0	367 21 241 0	067 22 244 3	367 22 254 3	367 23 218 4	134/100	367 14 219 0	367 14 220 0			
2	FA-272/N6												
3	-273/N6	20	467 20 215 0	467 21 213 0	067 22 244 3	367 22 254 3	367 23 218 4	134/120	367 14 219 0	367 14 220 0			
4	FA-273/N6	20											
5	-273H12/N6	20	467 20 215 0	467 21 213 0	067 22 244 3	367 22 254 3	367 23 218 4	134-35/120	367 14 219 0	367 14 220 0			
6	FA-273H12/N6												
7	FA-273/N9	20	467 20 248 0	467 21 213 0	067 22 244 3	367 22 347 3	367 23 218 4	134/120	367 14 219 0	367 14 220 0			
8													
9													
10													
11													
12													
13													
14													
15													
16													
17	-272/N6	22	467 20 218 0	467 21 216 0	067 22 277 3	367 22 241 3	367 23 214 4	134/100	367 14 219 0	367 14 220 0			
18	FA-272/N6												
19	-273/N6	22	467 20 218 0	467 21 240 0	067 22 277 3	367 22 241 3	367 23 214 4	134/120	367 14 219 0	367 14 220 0			
20	FA-273/N6												
21													
22													
23													
24													
25													
26													
27													
28													
29													
30													
31													
32													
33													
34													
35	-273/N6	24	467 20 228 0	467 21 229 0	067 22 245 3	367 22 316 3	367 23 217 4	134/120	367 14 223 0	367 14 224 0			
36	FA-273/N6												
37	-273/N12	24	467 20 240 0	467 21 229 0	067 22 245 3	367 22 339 3	367 23 217 4	134/120	367 14 223 0	367 14 224 0			
38	-274/N6	24	467 20 228 0	467 21 239 0	067 22 245 3	367 22 316 3	367 23 217 4	134/150	367 14 223 0	367 14 224 0			
39													
40													
41													
42													
43													
44													
45													
46													
47													
48													
49	-272/N6	26	367 20 243 0	367 21 244 0	067 22 413 3	367 22 255 3	367 23 221 4	134/100	367 14 223 0	367 14 224 0			
50													
51	-273/N6	26	367 20 243 0	367 21 242 0	067 22 413 3	367 22 255 3	367 23 221 4	134/120	367 14 223 0	367 14 224 0			
52													
53	-273H12/N6	26	367 20 243 0	367 21 242 0	067 22 413 3	367 22 255 3	367 23 221 4	134-35/120	367 14 223 0	367 14 224 0			
54	FA-272/N6	26	467 20 251 0	467 21 254 0	067 22 413 3	367 22 255 3	367 23 221 4	134/100	367 14 223 0	367 14 224 0			
55													
56													
57													
58													
59													
60													
61													
62													
63													
64													
65	-272/N6	28	367 20 249 0	367 21 251 0	067 22 390 3	367 22 293 3	367 23 231 4	134/100	367 14 225 0	367 14 226 0			
66	-272/N6	28	367 20 251 0	367 21 256 0	067 22 324 3	367 22 325 3	367 23 231 4	134/100	367 14 225 0	367 14 226 0			
67	-273/N6	28	467 20 237 0	467 21 243 0	067 22 390 3	367 22 293 3	367 23 231 4	134/120	367 14 225 0	367 14 226 0			
68	FA-272/N6	28	467 20 237 0	467 21 255 0	067 22 390 3	367 22 293 3	367 23 231 4	134/100	367 14 225 0	367 14 226 0			
69													
70													
71													
72													
73													
74													
75													
76													
77													
78													
79													
80													
81													
82													
83	-273/N6	30	367 20 233 0	367 21 229 0	067 22 380 3	367 22 240 3	367 23 219 4	134/120	367 14 225 0	367 14 226 0			
84	-273/N9	30	467 20 238 0	467 21 244 0	067 22 380 3	367 22 330 3	367 23 219 4	134/120	367 14 225 0	367 14 226 0			
85	-273H12/N6	30	367 20 233 0	367 21 229 0	067 22 380 3	367 22 240 3	367 23 219 4	134-35/120	367 14 225 0	367 14 226 0			
86													
87													
88													
89													
90													
91													

**467BN**









KH.11.81 ① Teil auf Wunsch für bestimmte Einsatzzwecke ● Garnitur auf Wunsch für bestimmte Einsatzzwecke, wobei Einzelteile auch in der Grundklasse sein können. ▲ Einzelteile siehe Blatt ①  
 JT.9.85 ▶ TV-Teil nur als Ersatz lieferbar  
 KH.7.89

A	B	C	D	E	F	G	H	J	K	L	M	N	O
Zweinadel mit kombinierten Ober-; Unter- und Nadeltransport Twin needle with unison feed												Gruppe: Nr. <b>F.3</b> Group:	
E-Nr.:	<b>467BN</b>	NA											
1													
2													
3													
4													
5													
6													
7													
8													
9													
10													
11													
12													
13													
14													
15													
16													
17													
18													
19													
20													
21													
22													
23													
24													
25													
26													
27													
28													
29													
30													
31													
32													
33													
34													
35													
36													
37													
38													
39													
40													
41													
42													
43													
44													
45													
46													
47													
48													
49													
50													
51													
52													
53													
54													
55													
56													
57													
58													
59													
60													
61													
62													
63													
64													
65													
66													
67													
68													
69													
70													
71													
72													
73													
74													
75													
76													
77													
78													
79													
80													
81													
82													
83													
84													
85													
86													
87													
88													
89													
90													
91													

KH 11.81 ① Teil auf Wunsch für bestimmte Einsatzzwecke ● Garnitur auf Wunsch für bestimmte Einsatzzwecke, wobei Einzelteile auch in der Grundklasse sein können. ▲ Einzelteile siehe Blatt ①  
 J.T.9.85  
 KH.7.89

A	B	C	D	E	F	G	H	J	K	L	M	N	O
E-Nr.: <b>467BN</b>		NA											
1													
2													
3													
4													
5													
6													
7													
8													
9													
10													
11													
12													
13													
14													
15													
16													
17													
18													
19													
20													
21													
22													
23													
24													
25													
26													
27													
28													
29													
30													
31													
32													
33													
34													
35													
36													
37													
38													
39													
40													
41													
42													
43													
44													
45													
46													
47													
48													
49													
50													
51													
52													
53													
54													
55													
56													
57													
58													
59													
60													
61													
62													
63													
64													
65													
66													
67													
68													
69													
70													
71													
72													
73													
74													
75													
76													
77													
78													
79													
80													
81													
82													
83													
84													
85													
86													
87													
88													
89													
90													
91													

KH.1181 ① Teil auf Wunsch für bestimmte Einsatzzwecke ● Garnitur auf Wunsch für bestimmte Einsatzzwecke, wobei Einzelteile auch in der Grundklasse sein können ▲ Einzelteile siehe Blatt ①  
JT.9.85 KH.7.89

A	B	C	D	E	F	G	H	J	K	L	M	N	O
Zweifel mit kombinierten Ober-; Unter- und Nadeltransport Twin needle with unison feed												Gruppe: Nr. <b>G.0</b> Group:	
E-Nr.:	<b>467</b>	NA											
1													
2													
3		-273/N6	} 8	367 20 207 0	367 21 209 0	067 22 409 2 3	367 22 250 2 3	367 23 204 4	134/120	367 14 201 0	367 14 202 0		
4		FA-273/N6											
5													
6													
7													
8													
9		-273/N6	} 10	367 20 204 0	367 21 204 0	067 22 410 2 3	367 22 251 2 3	367 23 202 4	134/120	367 14 201 0	367 14 202 0		
10		FA-273/N6											
11													
12													
13													
14													
15		-273/N6	} 12	367 20 230 2 0	367 21 226 0	067 22 322 2 3	367 22 237 2 3	367 23 205 4	134/120	367 14 205 0	367 14 206 0		
16		FA-273/N6											
17													
18													
19													
20													
21		-273/N6	} 14	367 20 235 2 0	367 21 231 0	067 22 323 2 3	367 22 243 2 3	367 23 215 4	134/120	367 14 205 0	367 14 206 0		
22		FA-273/N6											
23													
24													
25													
26													
27		-273/N6	} 16	367 20 234 2 0	367 21 230 0	067 22 324 2 3	367 22 242 2 3	367 23 216 4	134/120	367 14 221 0	367 14 222 0		
28		FA-273/N6											
29													
30													
31													
32													
33		-273/N6	} 18	367 20 236 2 0	367 21 232 0	067 22 325 2 3	367 22 244 2 3	367 23 220 4	134/120	367 14 221 0	367 14 222 0		
34		FA-273/N6											
35													
36													
37													
38													
39		-273/N6	} 20	367 20 232 2 0	367 21 228 0	067 22 326 2 3	367 22 239 2 3	367 23 218 4	134/120	367 14 219 0	367 14 220 0		
40		FA-273/N6											
41													
42													
43													
44													
45		-273/N6	} 22	367 20 237 2 0	367 21 233 0	067 22 327 2 3	367 22 245 2 3	367 23 214 4	134/120	367 14 219 0	367 14 220 0		
46		FA-273/N6											
47													
48													
49													
50													
51		-273/N6	} 24	367 20 231 2 0	367 21 227 0	067 22 328 2 3	367 22 238 2 3	367 23 217 4	134/120	367 14 223 0	367 14 224 0		
52		FA-273/N6											
53													
54													
55													
56													
57													
58													
59													
60													
61													
62													
63													
64													
65													
66													
67													
68													
69													
70													
71													
72													
73													
74													
75													
76													
77													
78													
79													
80													
81													
82													
83													
84													
85													
86													
87													
88													
89													
90													
91													

speziell für  
Reißverschlüsse  
siehe  
Apparateliste  
special for  
Zipfastners  
see  
attachment list

KH.11.81 ① Teil auf Wunsch für bestimmte Einsatzzwecke ● Gamitur auf Wunsch für bestimmte Einsatzzwecke, wobei Einzelteile auch in der Grundklasse sein können. ▲ Einzelteile siehe letztes Blatt  
8.89 ▶ TV-Teil nur als ersatz lieferbar Mg = mustergebunden, bei Ersatzteilebestellung bitte Reißverschluss einschicken

## Teileliste und Näheinrichtungen Spare Parts List and Sewing Equipment

467

### Erläuterungen zur Ersatzteilleiste

#### 1. Allgemeines

Separate Ersatzteilleisten gibt es fuer : Naehgarnituren, Naehkopfabhaengige Zusatzausstattungen.

#### 2. Kennzeichnung der Ersatzteile

Zu einer Einheit gehoernde Einzelteile sind durch eine strichpunktierte Linie eingerahmt. Die Einheit kann auch komplett unter der voll eingerahmten Nr. (in einem Kasten) bestellt werden. Zu dieser Einheit gehoeren keine Teile, deren Nr. ausserhalb der strichpunktierten Linie steht.

Teile, die mit "N" gekennzeichnet sind, werden nicht einzeln geliefert.

Sollten Sie ein Teil nicht in der Ersatzteilleiste auffinden, was durch technische Aenderungen vorkommen kann, dann geben Sie uns bitte zur Teile- und Funktionsbeschreibung die genaue Unterklasse und Fabrik-Nr. lt. Typenschild bekannt.

Bei Bestellungen von Elektroteilen bitten wir die zusaetzlichen Angaben, die in Klammern hinter der Teile-Nr. stehen, mit anzugeben.

Im Inhaltsverzeichnis sind die Teile-Nr. nach steigenden Nr. geordnet. Ausserdem sind angegeben :

Teile-Nr. 993 91 083 8 Zyl. Schr. M 4 x 10 3 - B1  
 Benennung \_\_\_\_\_  
 Abmessung \_\_\_\_\_  
 Bildtafel Nr. (rechts und links oben in der Bildtafel eingekreiste Nr.) \_\_\_\_\_  
 Planquadrat der jeweiligen Bildtafel \_\_\_\_\_

#### 3. Verwendete Bildzeichen

	= siehe Mechanikeranleitung		= ohne Fadenabschneider		= Hinweis auf Unterscheidungsmerkmal		= 1 Nadel
	= fluessig sichern, kleben, dichten Loctite 270, Nr. 990 49 034 6		= mit Fadenabschneider	mm	= Maße		= 2 Nadeln
	= fluessig sichern, kleben, dichten Loctite IS-460, Nr. 990 49 037 1		= links	V	= veraltete Ausfuehrung		
	= Laenge oder Flaechen angeben		= rechts	a.W.	= auf Wunsch		

#### 4. Handhabung der Ersatzteilleiste

Taetigkeit :

Blaetter der Ersatzteilleiste: Erklaerung :

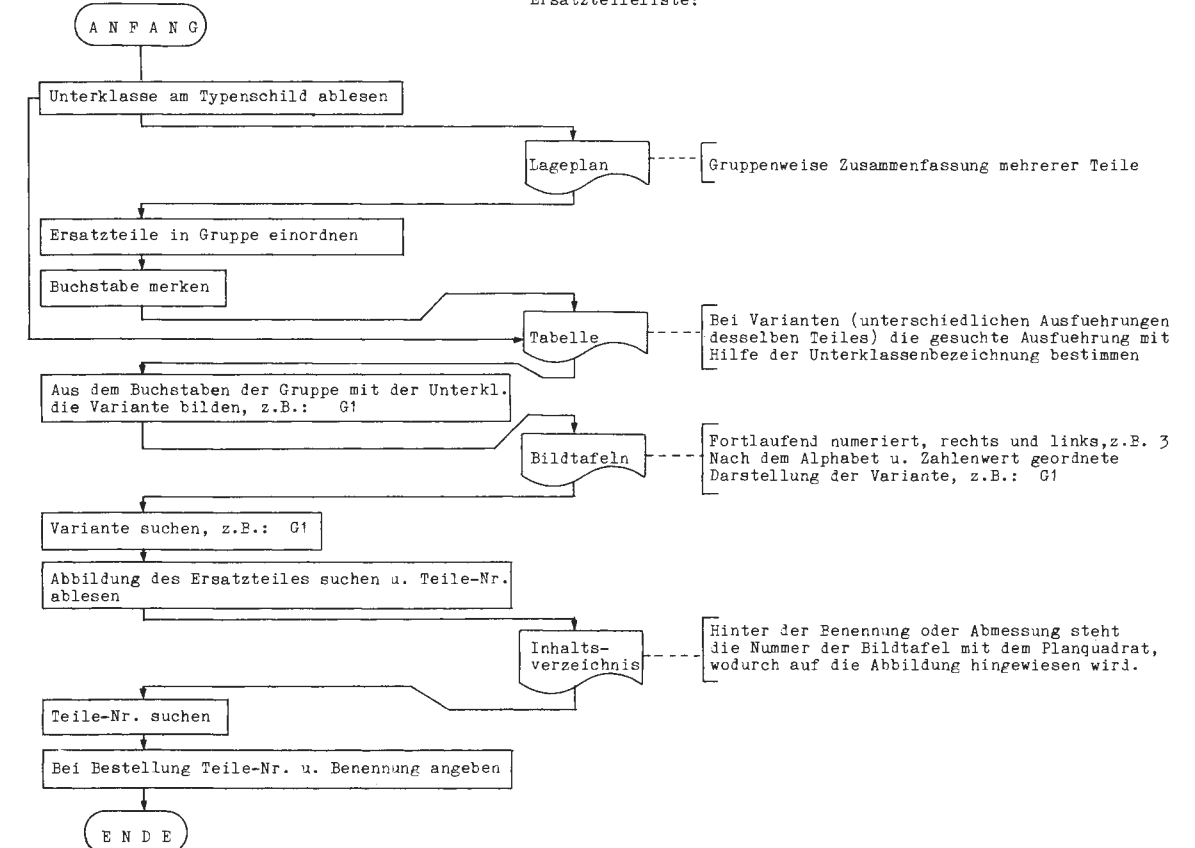

5. Jeder Nachdruck, auch auszugsweise, ist nur mit unserer Genehmigung gestattet. Aenderungen behalten wir uns vor.

Gr.D.1

Explanation of spare parts list

1. In general

Separate lists are available for sewing components, sewing-machine dependent additional equipment.

2. Numbering of parts

The component parts of a complete unit are framed by a dot-dash line. The unit can also be ordered complete by quoting the number enclosed in the full lined "box" contained within the dot-dash frame. Any parts, the numbers of which are outside of the frame, are not part of the unit and must be ordered separately.

Parts marked with "N" cannot be supplied singly.

If a part cannot be found in the parts list, possibly due to technical alteration, when ordering, please describe the part and function fully, quoting the sub-class and serial number of the machine according to the specification plate.

When ordering electrical parts, please include the additional information set in brackets after the part number.

In the table of contents the part numbers are listed in numerical order, e.g.

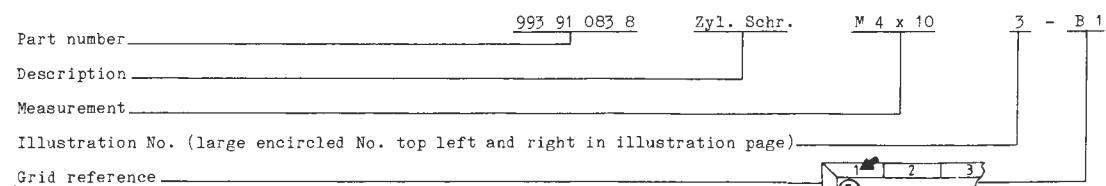

3. Symbols applied

	= see mechanics manual		= without thread cutter		= point of alteration		= 1 needle
	= secure by glueing, seal Loctite 270, No. 990 49 034 6		= with thread cutter	<b>mm</b>	= measurement		= 2 needles
	= secure by glueing, seal Loctite IS-460, No. 990 49 037 1		= left	<b>V</b>	= obsolete		
	= declare length or area		= right	<b>d.W.</b>	= on request		

4. Using the parts list

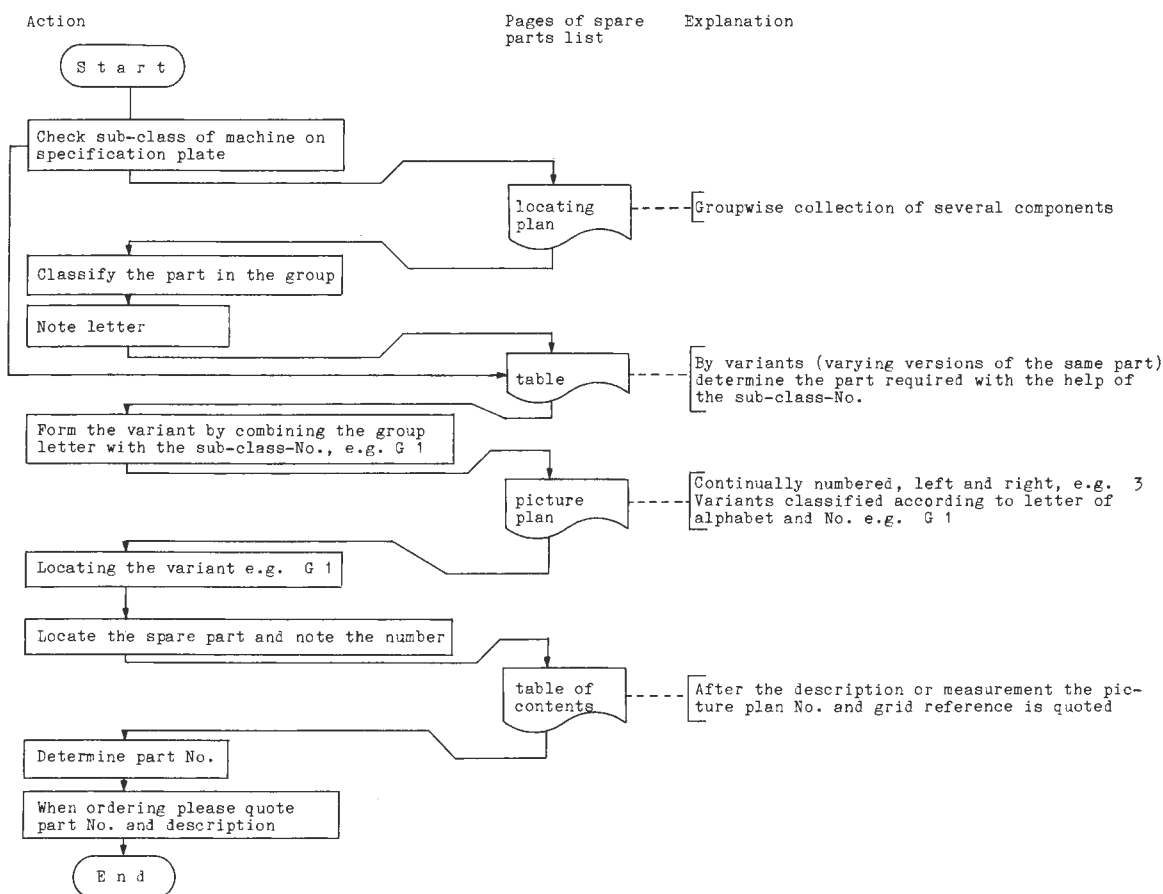

5. All reproductions, also in part, require our permission. Subject to alteration.

Gr.D.1

Explications pour la liste de pièces de rechange

1. Généralités

Il existe des listes de pièces de rechange séparément pour : jeux de pièces de couture, Equipements supplémentaires dépendant de la machine à coudre

2. Identification des pièces de rechange

Les pièces individuelles faisant partie d'une unité ont été encadrées d'une ligne à point-trait. L'unité peut être commandée aussi sous le numéro complètement encadré. Aucune pièce dont le numéro se trouve en dehors de l'encadrement n'appartient à cette unité.

Les pièces marquées par "N" ne sont pas livrables séparément.

Dans le cas où une pièce de rechange n'est pas indiquée dans la liste de pièces de rechange, ce qui peut se produire au cours de changements techniques, en cas de commande, veuillez indiquer la sous-class exacte ainsi que le numéro de fabrication de la machine selon le matricule.

Dans le cas de commande de pièces électriques veuillez également donner les indications supplémentaires qui se trouvent entre parenthèses après le numéro de la pièce.

Dans le table de matière les numéros des pièces sont indiqués par ordre numérique. En outre sont indiqués :

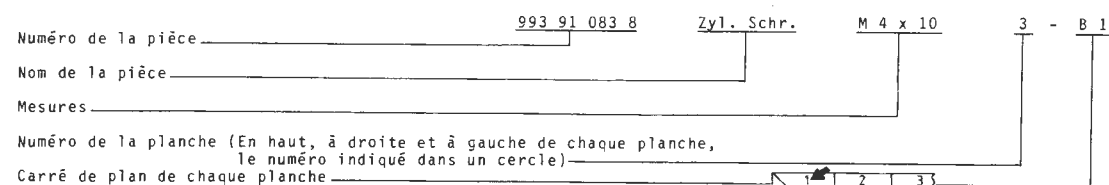

3. Symboles utilisés

	= voir instructions pour le mécanicien		= sans coupe-fil		= indication pour point de variation		= 1 aiguille
	= coller, fermer hermétiquement Loctite 270, No. 990 49 034 6		= avec coupe-fil	<b>mm</b>	= mesures		= 2 aiguilles
	= coller, fermer hermétiquement Loctite IS-460, No. 990 49 037 1		= gauche	<b>V</b>	= ancien model		
	= indiquer longueur ou surface		= droite	<b>d.W.</b>	= sur demande		

4. Emploi correct de la liste de pièces de rechange

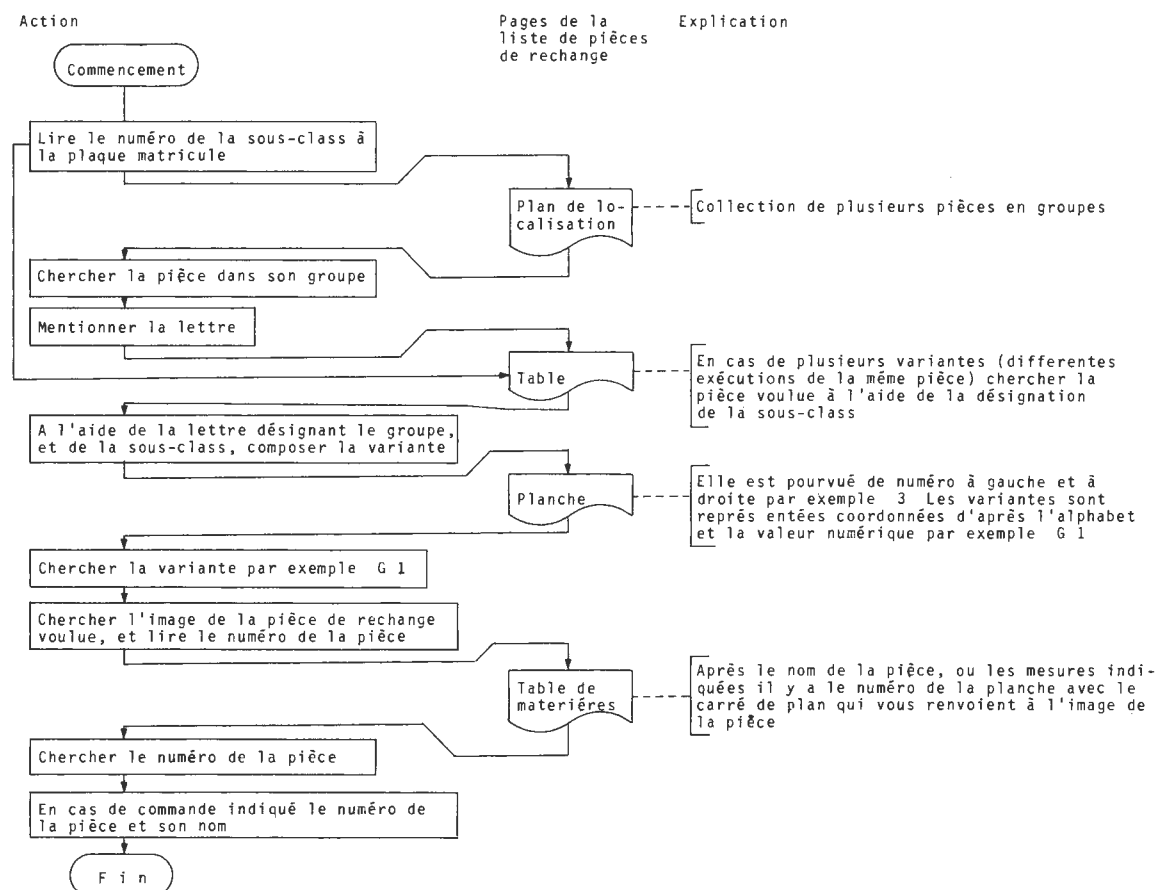

5. Toute reproduction, même en partie, n'est autorisée qu'avec notre permis. Nous nous réservons le droit de change

Gr.D.1



Aclaraciones a la lista de piezas de repuesto

1. Generalidades

Listas de piezas de repuesto por separado las hay para juegos de costura y equipos extra en función con el cabezal de coser.

2. Marcado de las piezas de requesto

Las piezas sueltas pertenecientes a una unidad están encuadradas por una raya de puntos. La unidad también se puede pedir completa con el número encuadrado por completo (en un cajetín). A esta unidad no pertenece ninguna pieza cuyo número quede fuera de la raya punteada.

Las piezas señaladas con una "N" no se sirven solas.

Si no encuentra usted una pieza en la lista de piezas de requesto - cosa que puede ocurrir por haber variaciones técnicas -, indíquenos entonces, junto a la descripción de la pieza y su función, la subclase exacta y el número de fábrica que figura en la placa del tipo.

En los pedidos de piezas eléctricas rogamos que también se nos indiquen los datos adicionales que figuran entre paréntesis detrás del número de la pieza.

En el sumario figuran los números de las piezas en progresión ascendente. Además se indican:

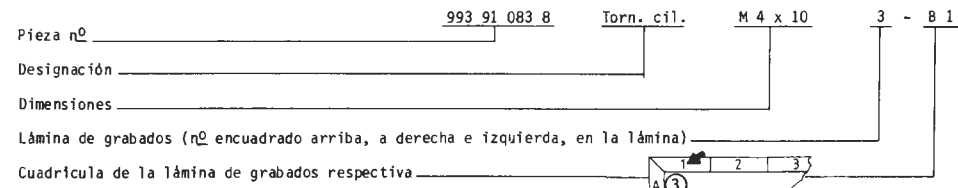

3. Símbolos empleados

	= Véase Instrucciones para el mecánico		= Sin cortahilos		= Advertencia de que hay diferencia de característica		= 1 aguja
	= Asegurar con líquido, pegar, obturar Loctite 270, nº 990 49 034 6		= Con cortahilos	mm	= medidas		= 2 agujas
	= Asegurar con líquido, pegar, obturar Loctite IS-460, nº 990 49 037 1		= izquierda	V	= ejecución antigua		
	= Indicar largo y superficie		= derecha	α.W.	= a petición		

4. Forma de proceder con la lista de piezas de repuesto

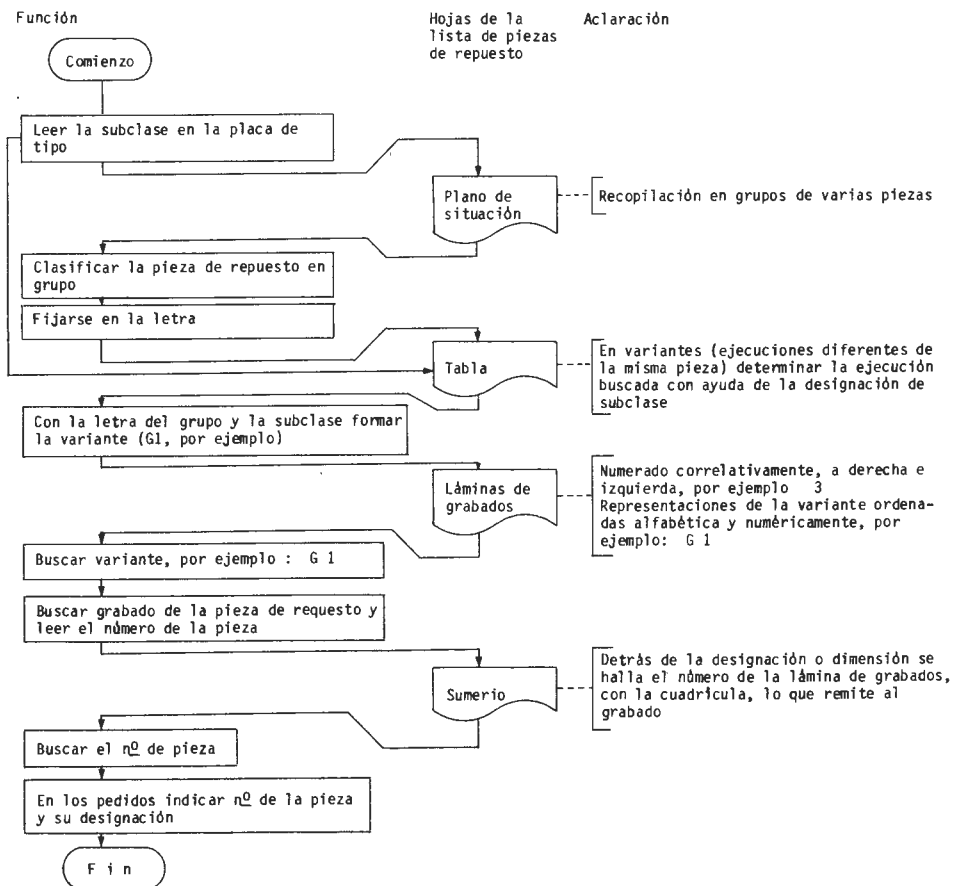

5. Toda reproducción, incluso extractada, sólo está permitida con nuestra autorización. Nos reservamos el derecho a hacer modificaciones.

Gr.D.1

SPIEGAZIONE SUL LIBRETTO PARTI DI RICAMBIO

1. Generalità

Esistono libretti parti di ricambio separati per: "Organi di cucitura", equipaggiamenti supplementari dipendenti dalla testa della macchina per cucire

2. Contrassegni dei pezzi di ricambio

Pezzi singoli componenti un gruppo sono racchiusi in una linea a punti e tratti. Il gruppo può essere anche ordinato completo indicando all'ordine il numero di pezzo incorniciato da una linea continua. I pezzi il cui numero è situato fuori della linea a punti e tratti non appartengono al gruppo

Pezzi contrassegnati con la lettera N non possono essere forniti come pezzo singolo

Nel caso che un pezzo non si trovi nel libretto parti di ricambio, ciò può succedere a causa delle continue innovazioni tecniche, indicate, accanto alla descrizione della funzione del pezzo e l'eventuale schizzo o descrizione minuta del pezzo, la classe e sottoclasse esatta ed il numero di fabbricazione riportati in targhetta

Ordinando componenti elettrici indicare i dati supplementari segnati in parentesi dietro il numero del pezzo

Nell'indice i numeri dei pezzi sono ordinati secondo numero progressivo ed inoltre sono indicati:

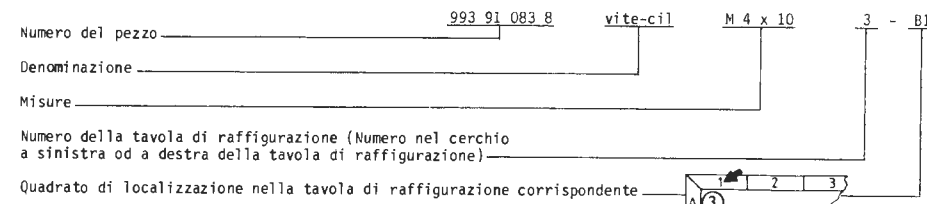

3. Simboli figurati utilizzati

	= Vedi libretto istruzioni per i meccanici		= Senza rasafilo		= Indicazione per notare le differenze tra i pezzi		= 1 ago
	= Fissaggio, incollaggio o tenuta del pezzo tramite liquido Loctite 270, Nr. 990 48 034 6		= Con rasafilo	mm	= Misura		= 2 aghi
	= Fissaggio, incollaggio o tenuta del pezzo tramite liquido Loctite IS-460, Nr. 990 49 037 1		= Sinistra (o)	V	= Esecuzione invecchiata		
	= Indicare la lunghezza o la superficie		= Destra (o)	α.W.	= A richiesta		

4. Uso del libretto parti di ricambio

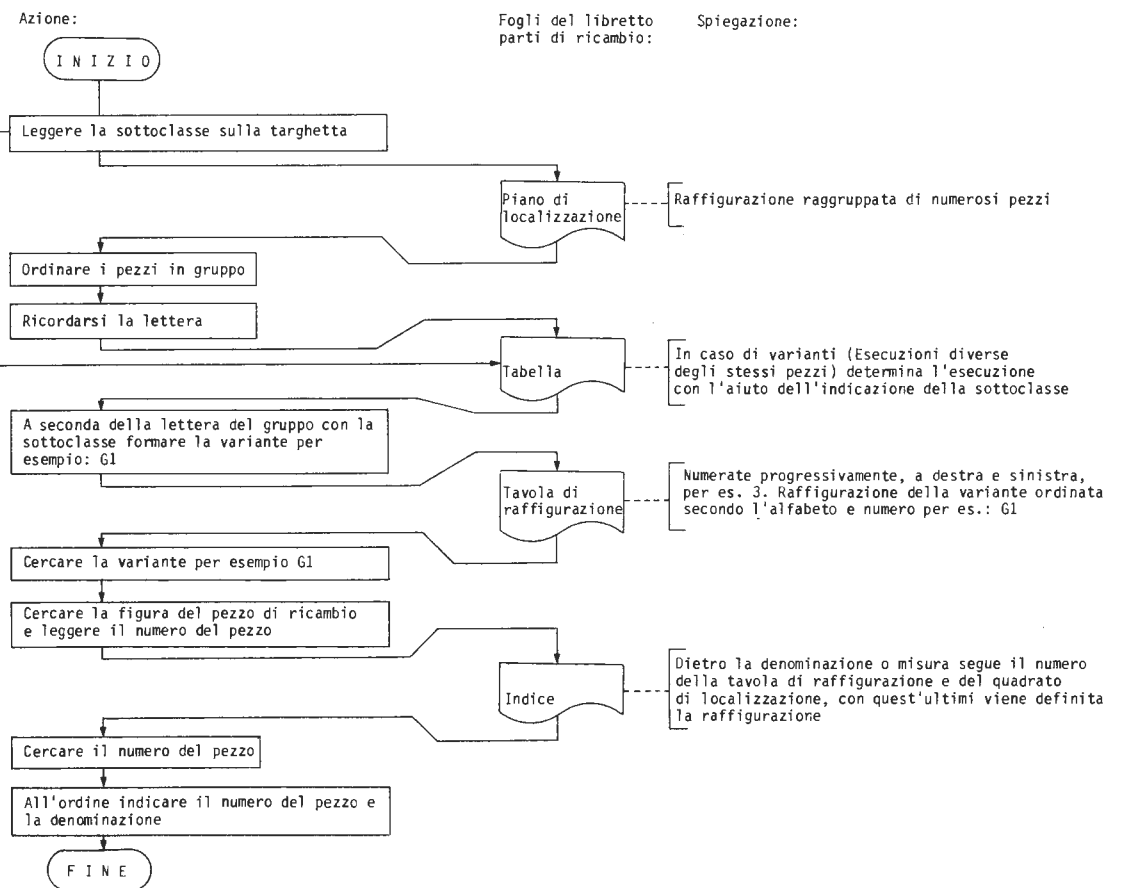

5. Ogni riproduzione intera o parziale è permessa solo con la nostra approvazione. Ci riserviamo ogni diritto di modifica.

Gr.D.1



# Lageplan 467 Situation plan

A - B - C	=	①
D - E - F	=	②
G - H - J - K	=	③ ③
L - M	=	④
N	=	⑤
O ohne FA	=	⑥
O mit FA	=	⑦
P	=	⑧
Q - R	=	⑨
S - T	=	⑩
S - V	=	⑪
U - W	=	⑫

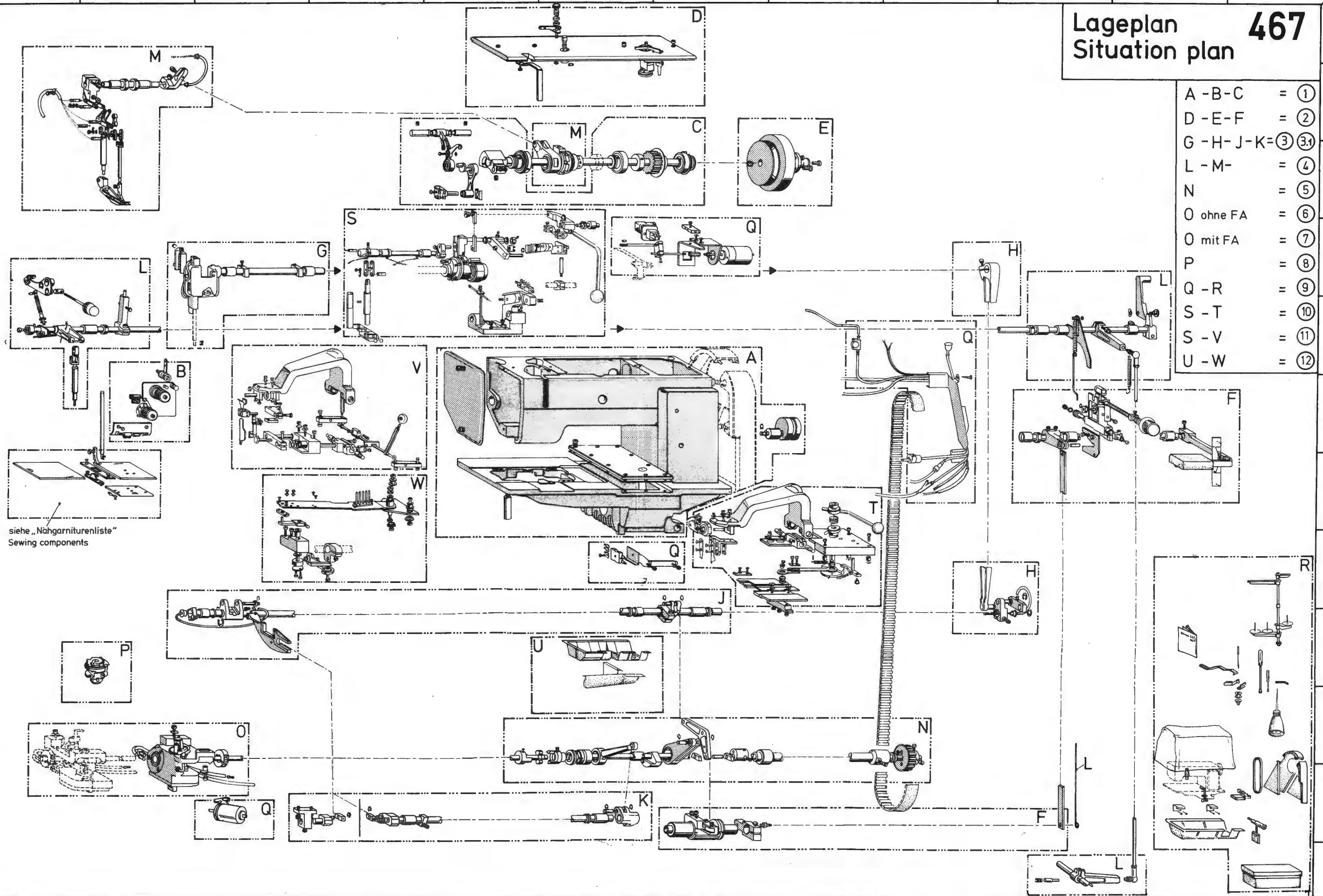

siehe „Nähgarniturenliste“  
Sewing components





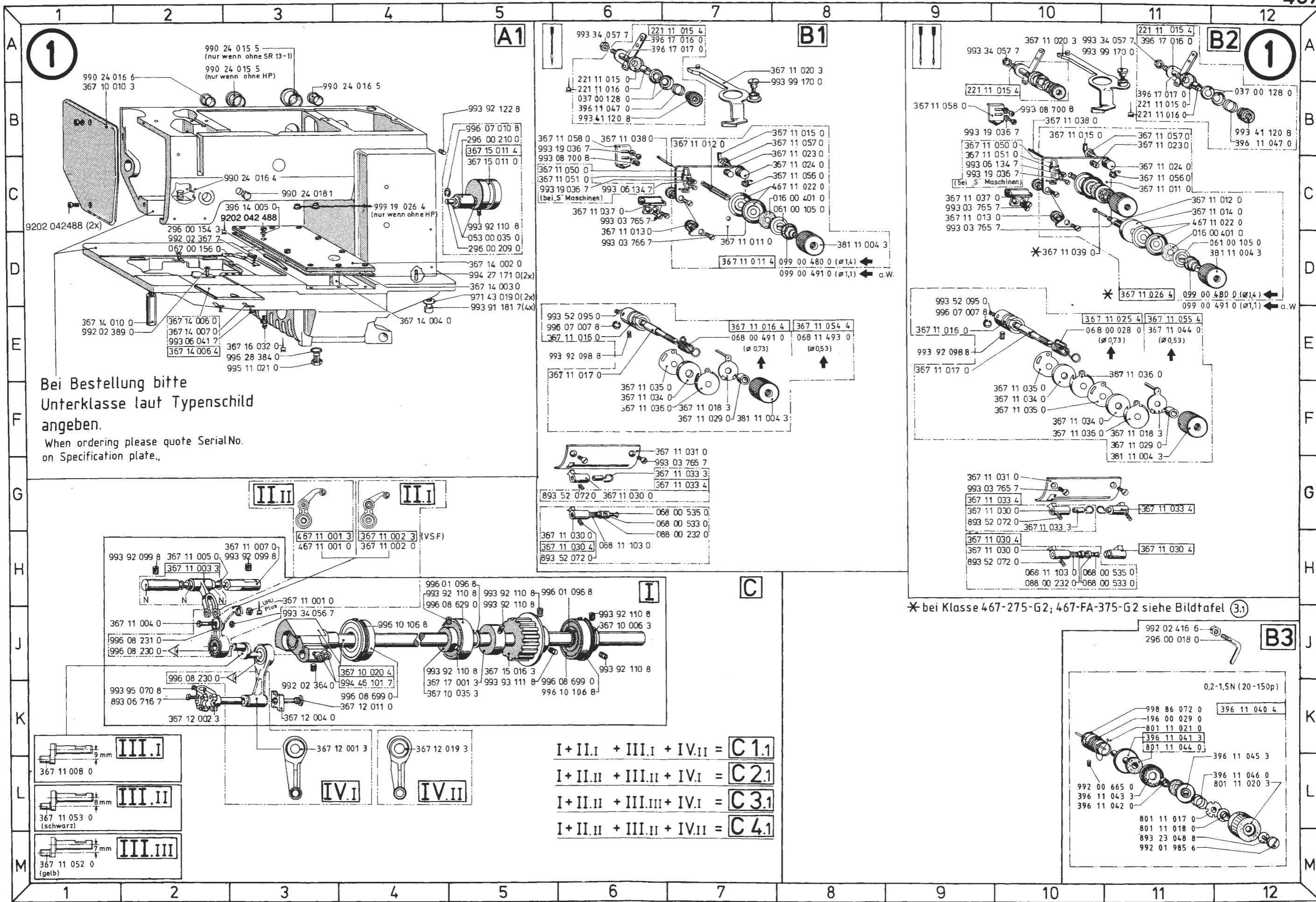

Bei Bestellung bitte  
Unterklasse laut Typenschild  
angeben.  
When ordering please quote SerialNo.  
on Specification plate.,

\* bei Klasse 467-275-G2; 467-FA-375-G2 siehe Bildtafel 3.1

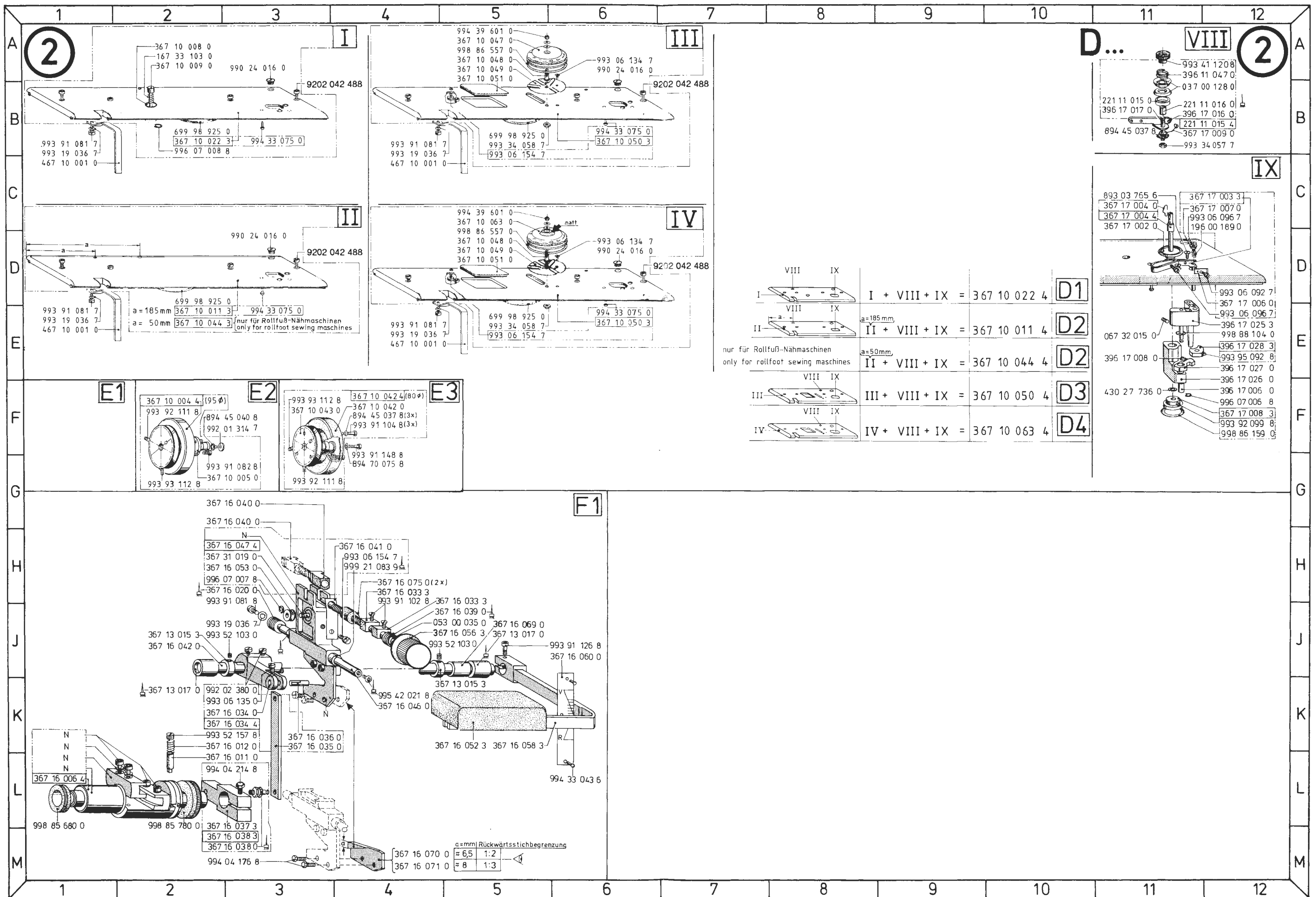

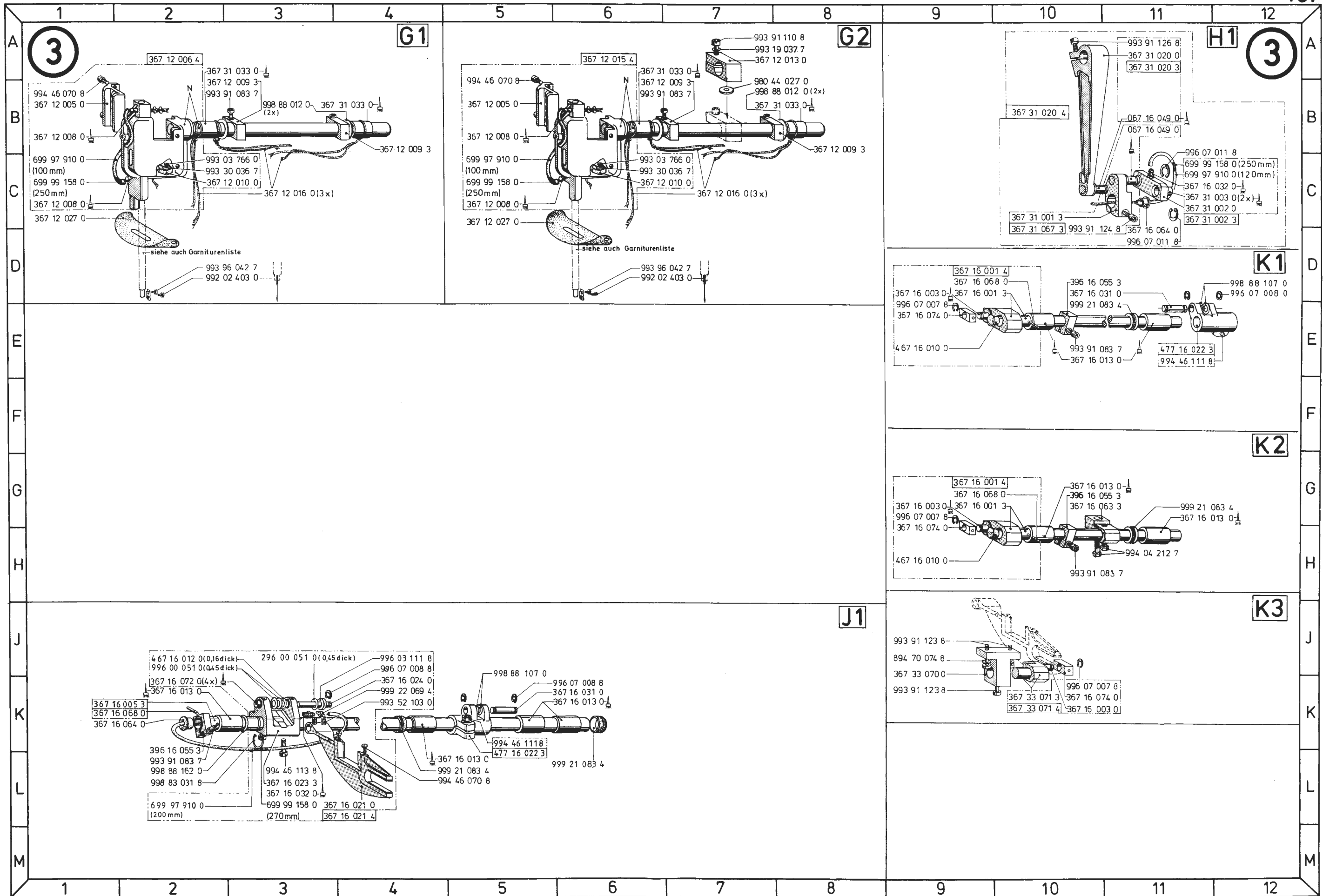



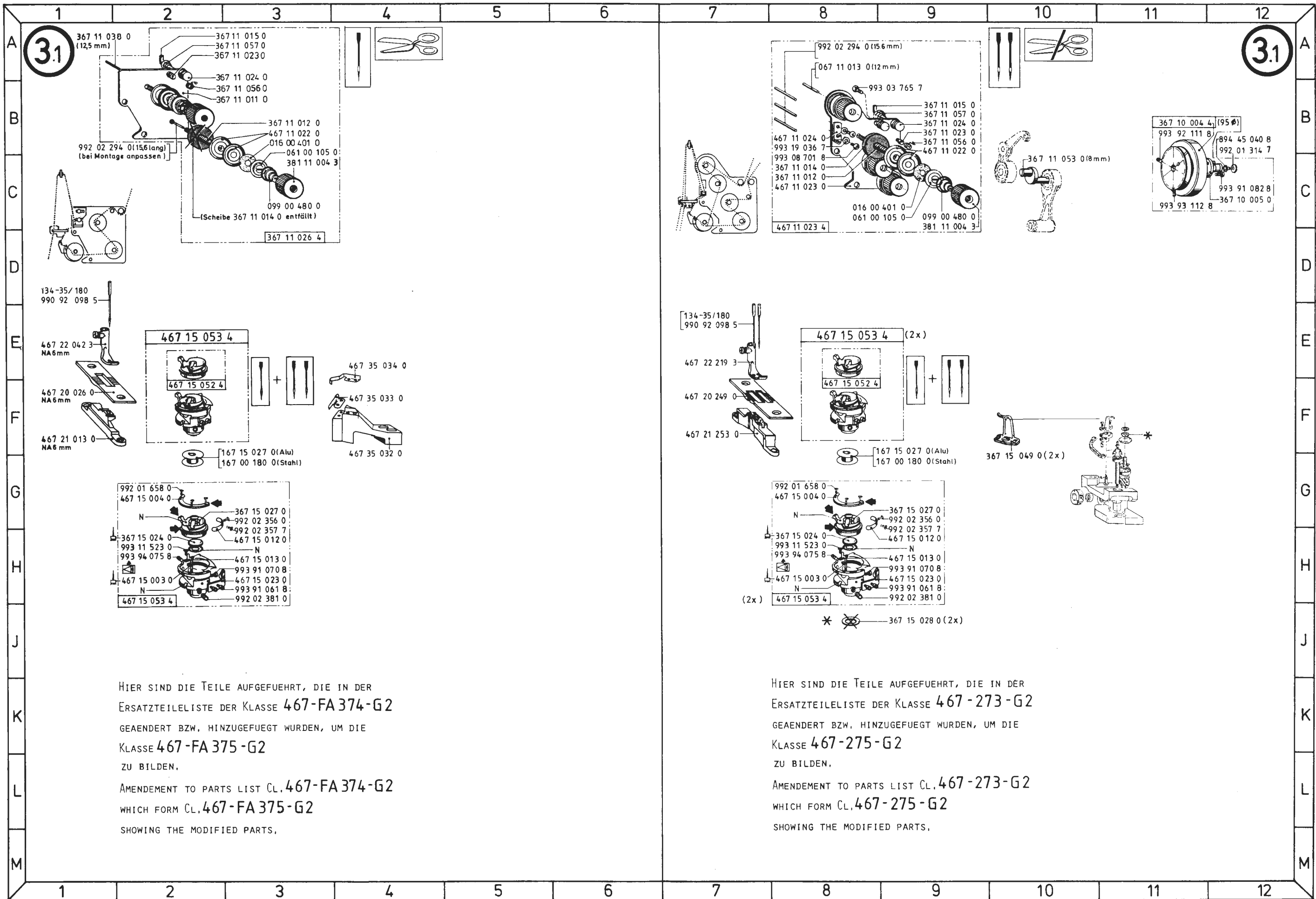

HIER SIND DIE TEILE AUFGEFUEHRT, DIE IN DER  
 ERSATZTEILELISTE DER KLASSE 467-FA 374-G2  
 GEANDERT BZW. HINZUGEFUEGT WURDEN, UM DIE  
 KLASSE 467-FA 375-G2  
 ZU BILDEN.  
 AMENDMENT TO PARTS LIST CL. 467-FA 374-G2  
 WHICH FORM CL. 467-FA 375-G2  
 SHOWING THE MODIFIED PARTS.

HIER SIND DIE TEILE AUFGEFUEHRT, DIE IN DER  
 ERSATZTEILELISTE DER KLASSE 467-273-G2  
 GEANDERT BZW. HINZUGEFUEGT WURDEN, UM DIE  
 KLASSE 467-275-G2  
 ZU BILDEN.  
 AMENDMENT TO PARTS LIST CL. 467-273-G2  
 WHICH FORM CL. 467-275-G2  
 SHOWING THE MODIFIED PARTS.

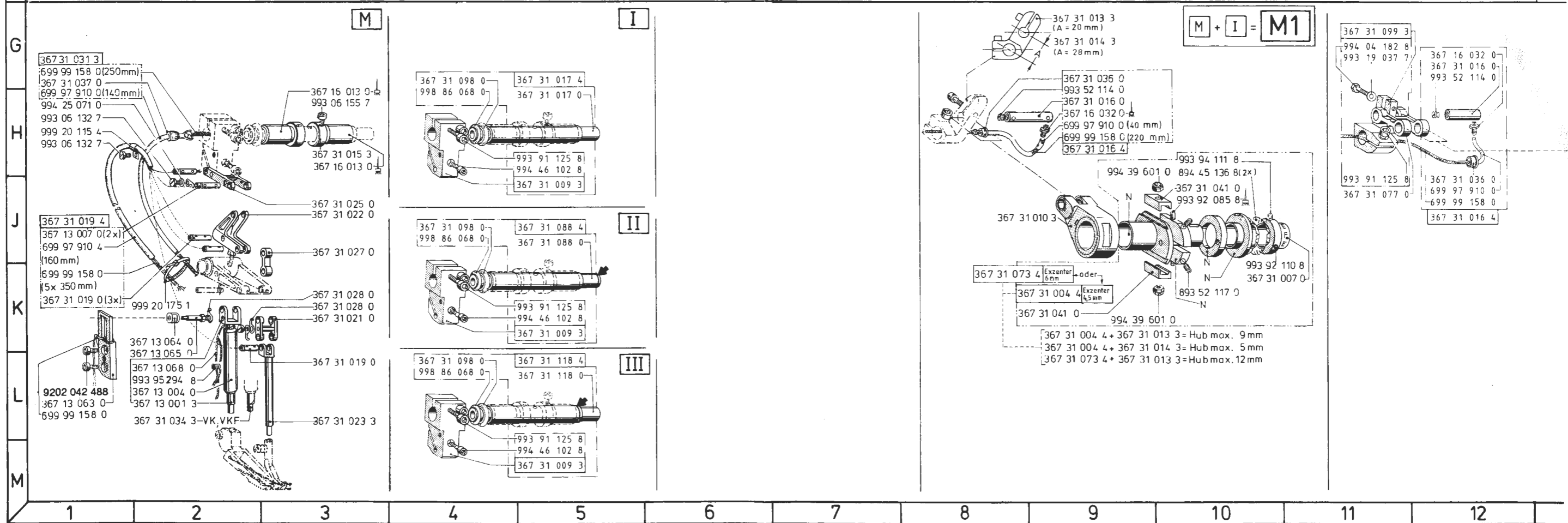
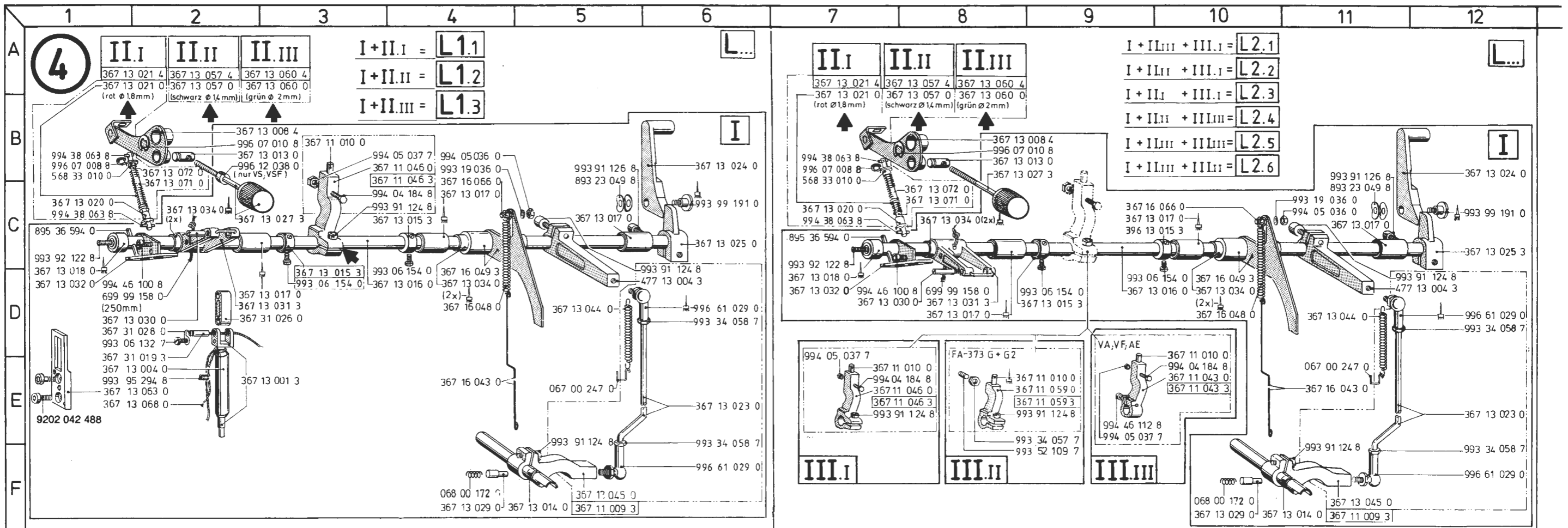

4

4

M2

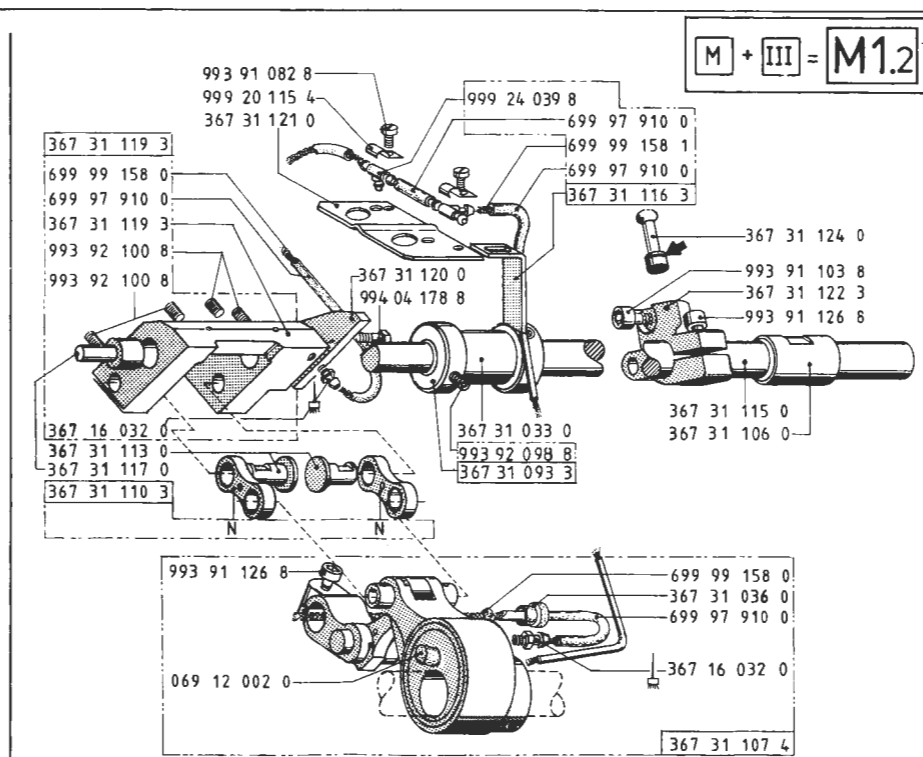
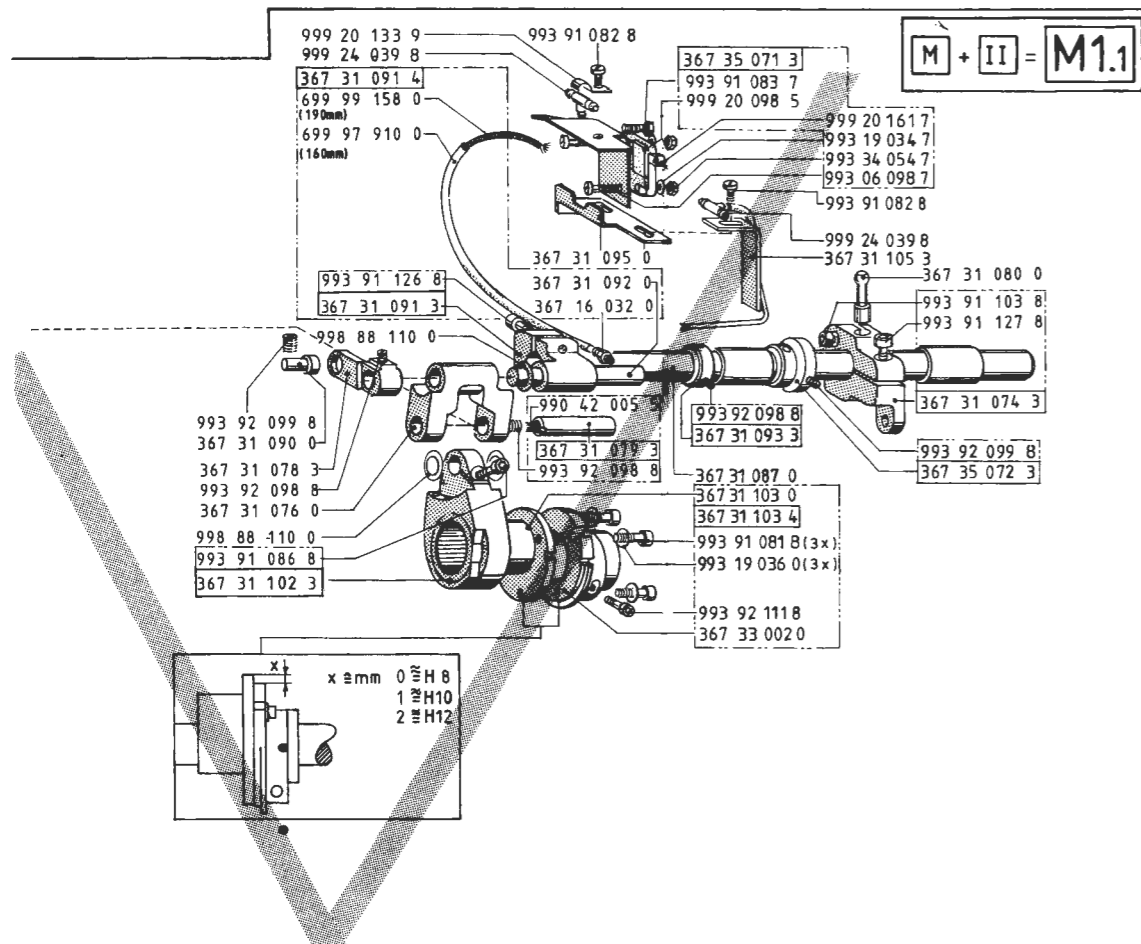
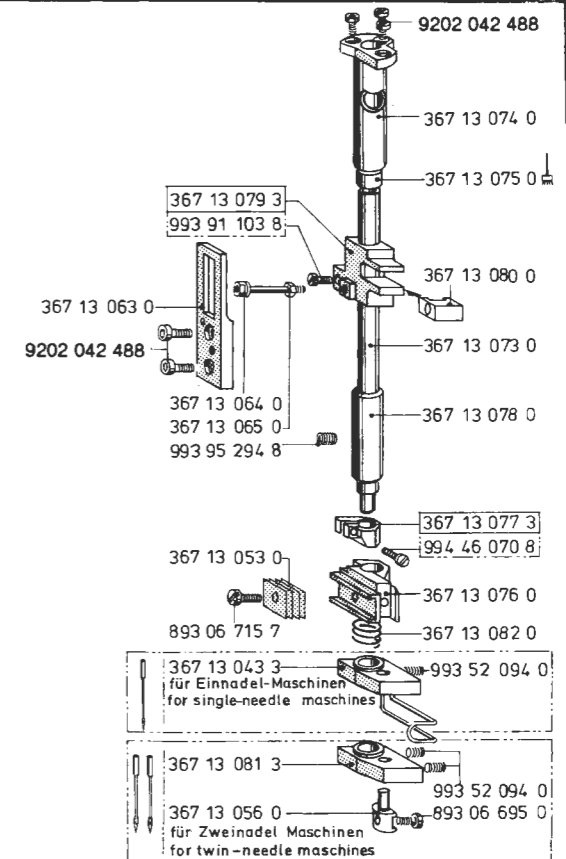
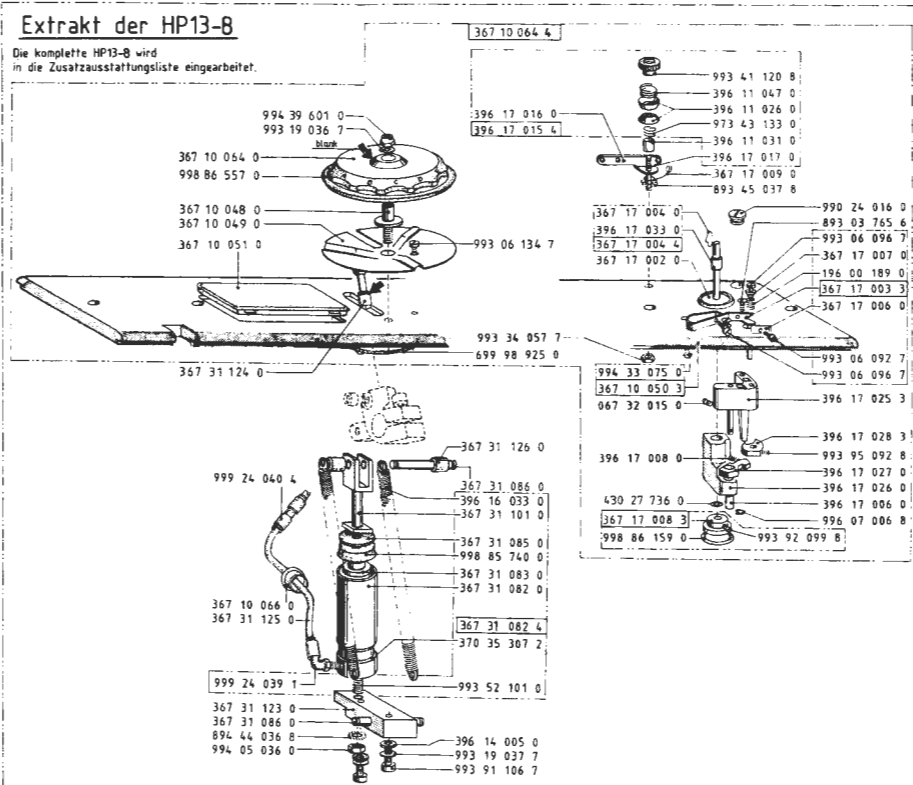



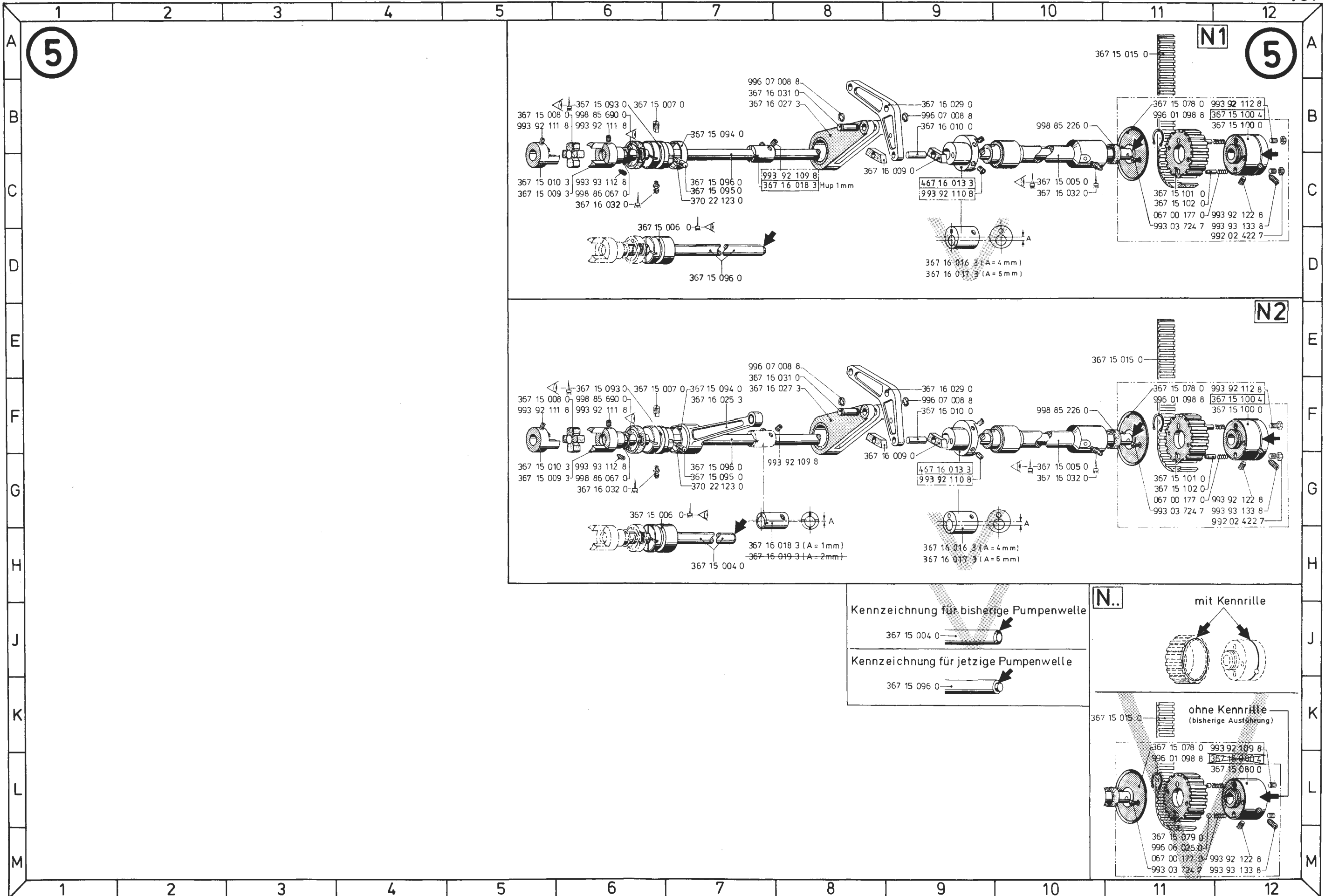

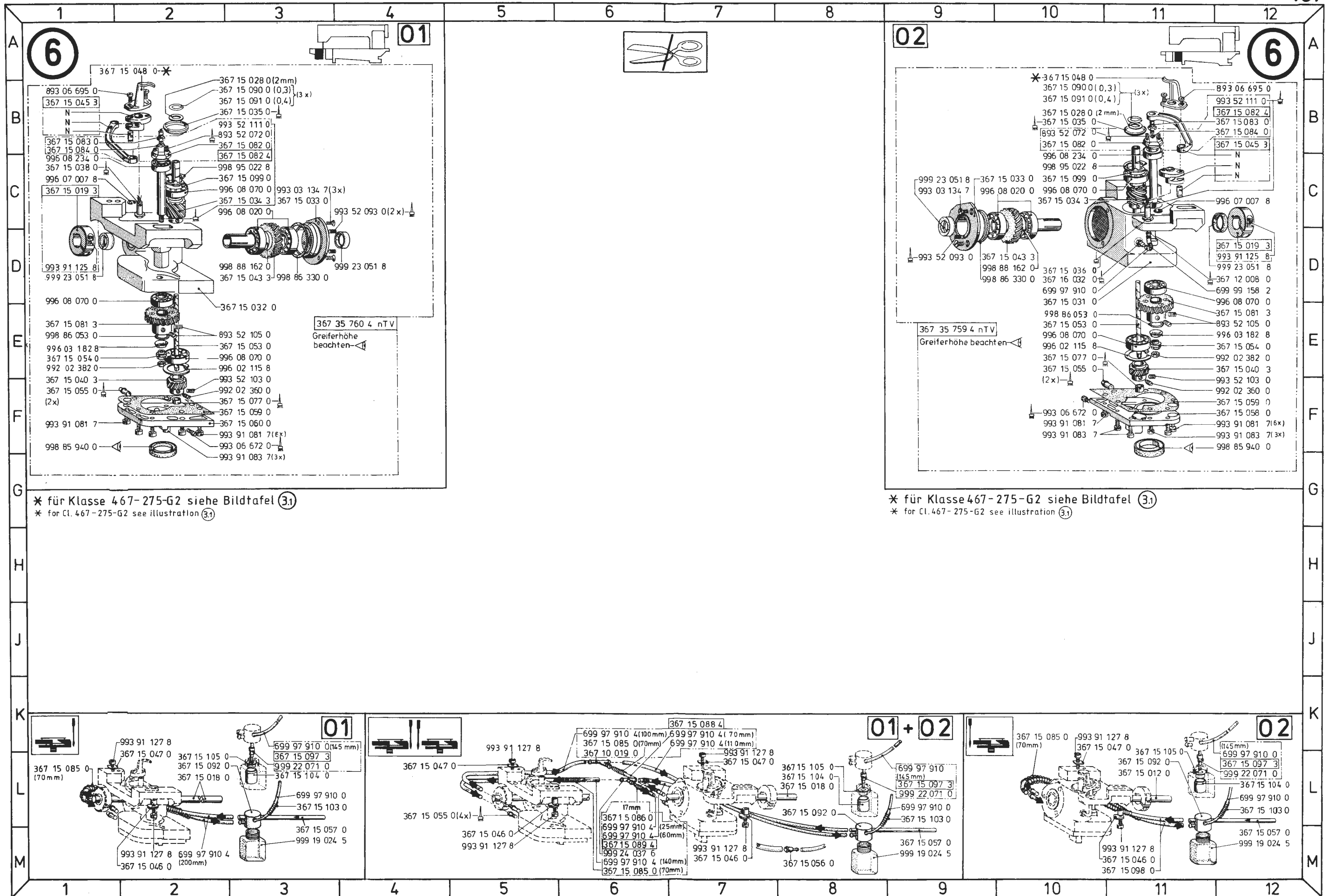

\* für Klasse 467-275-G2 siehe Bildtafel (3.1)  
 \* for Cl. 467-275-G2 see illustration (3.1)

\* für Klasse 467-275-G2 siehe Bildtafel (3.1)  
 \* for Cl. 467-275-G2 see illustration (3.1)



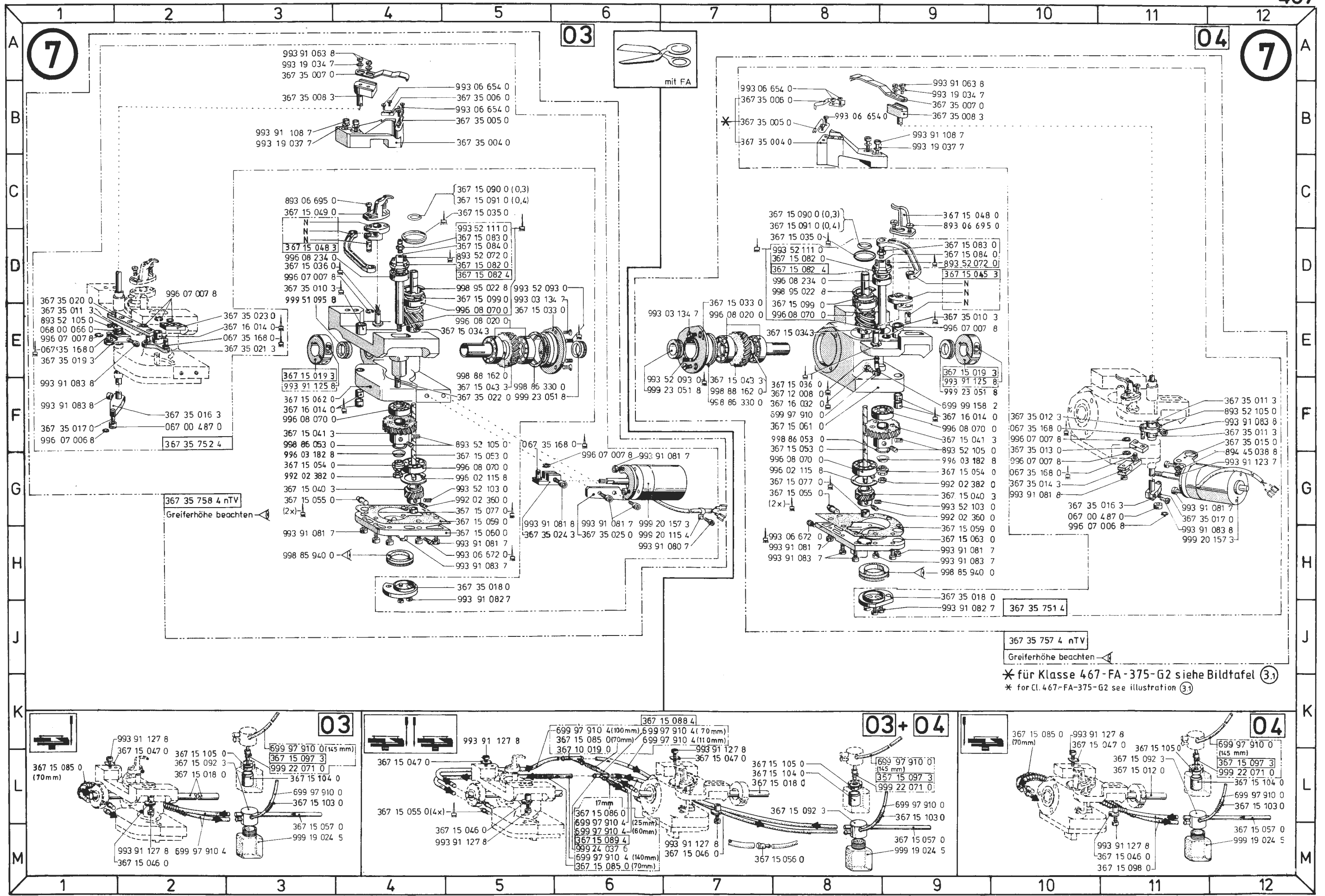

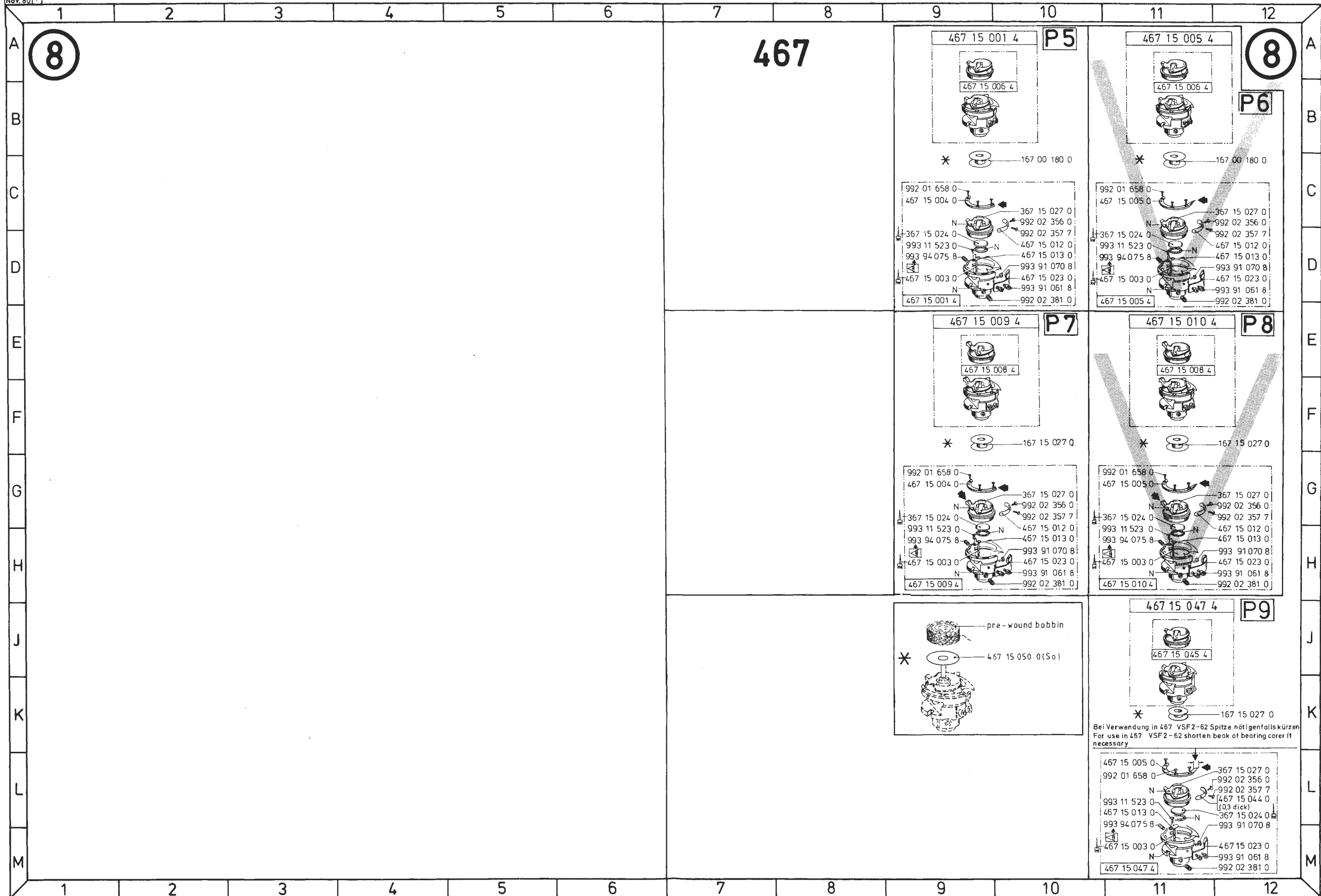



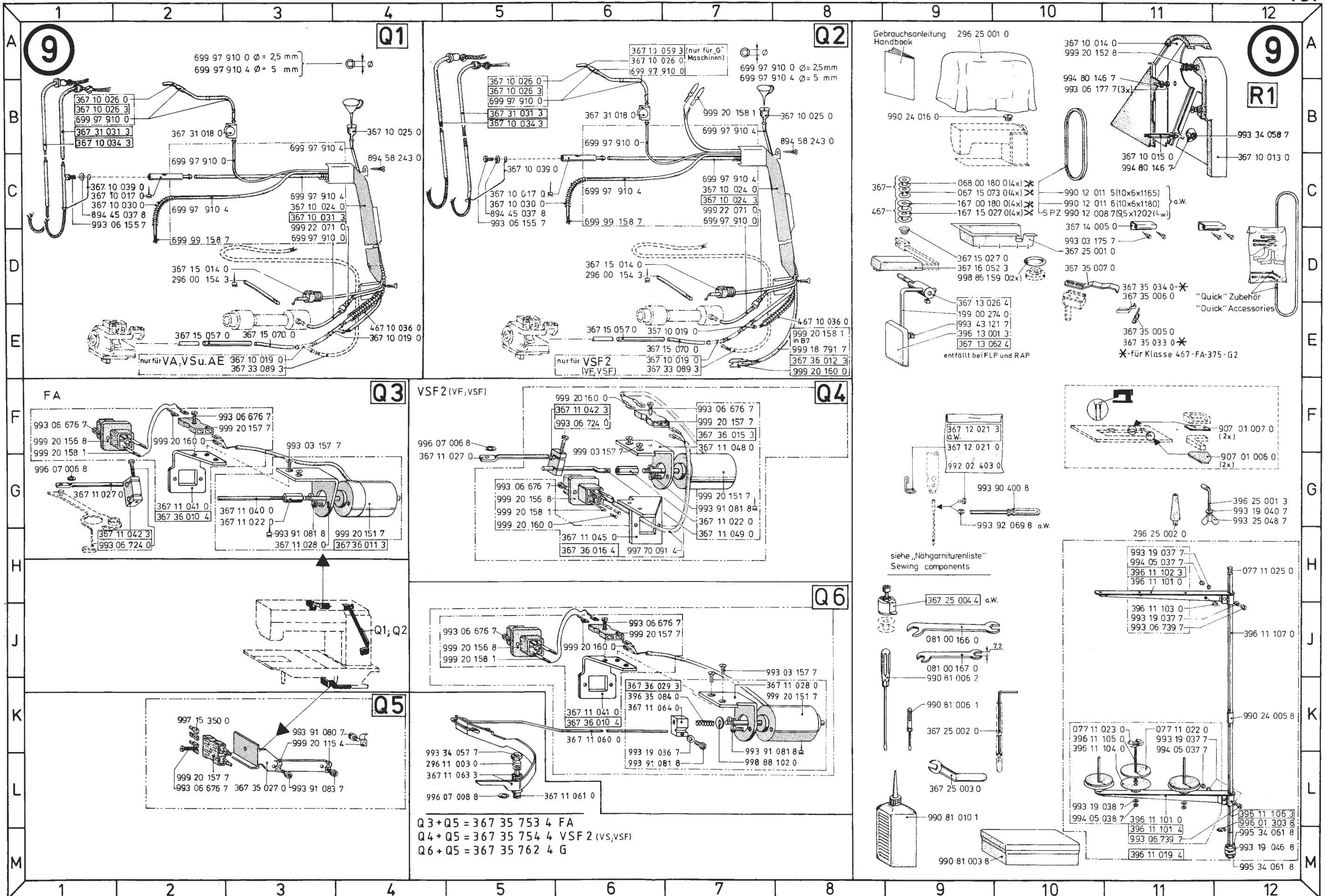

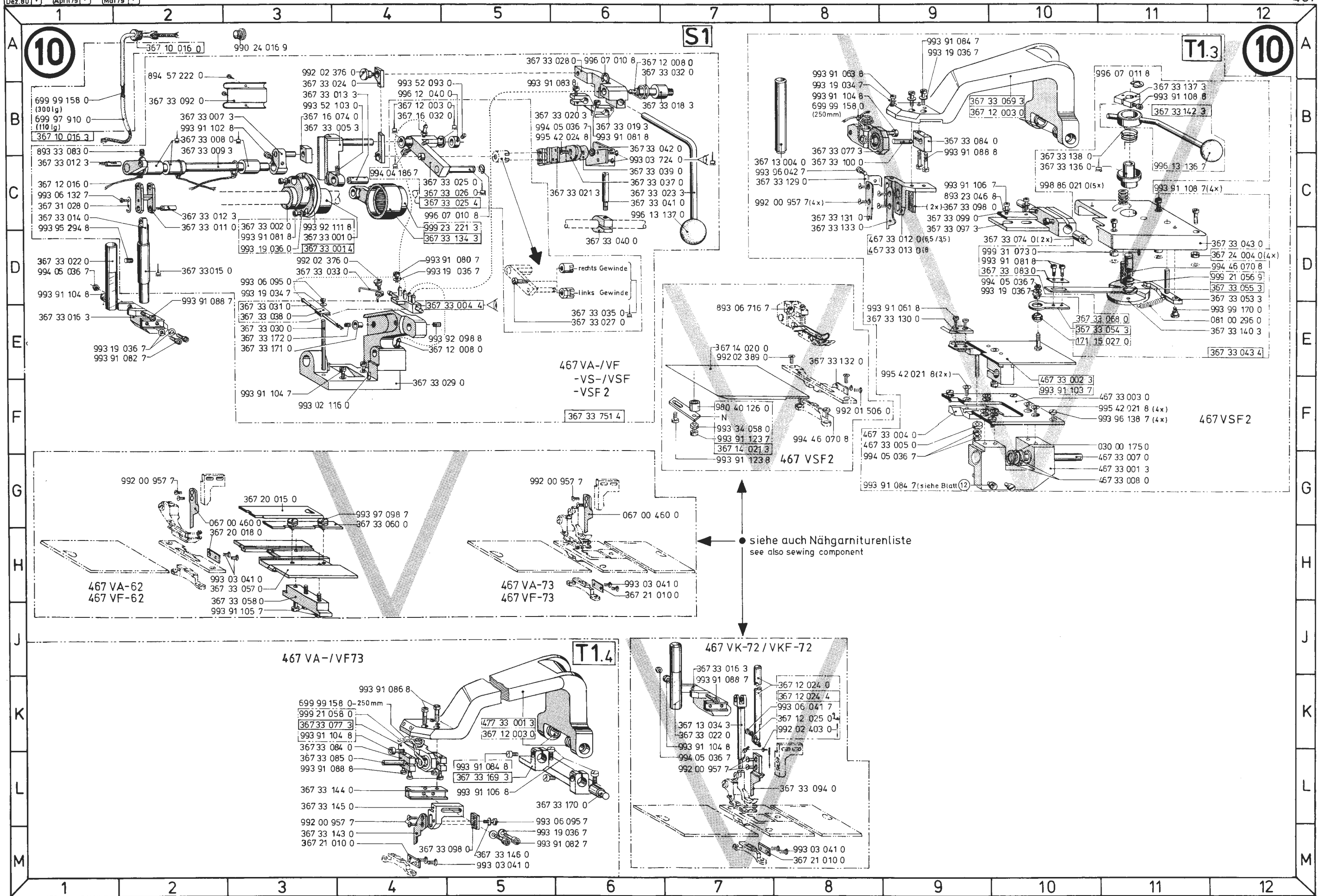



1 2 3 4 5 6 7 8 9 10 11 12

A 11

11 A

467 AE-73 S2

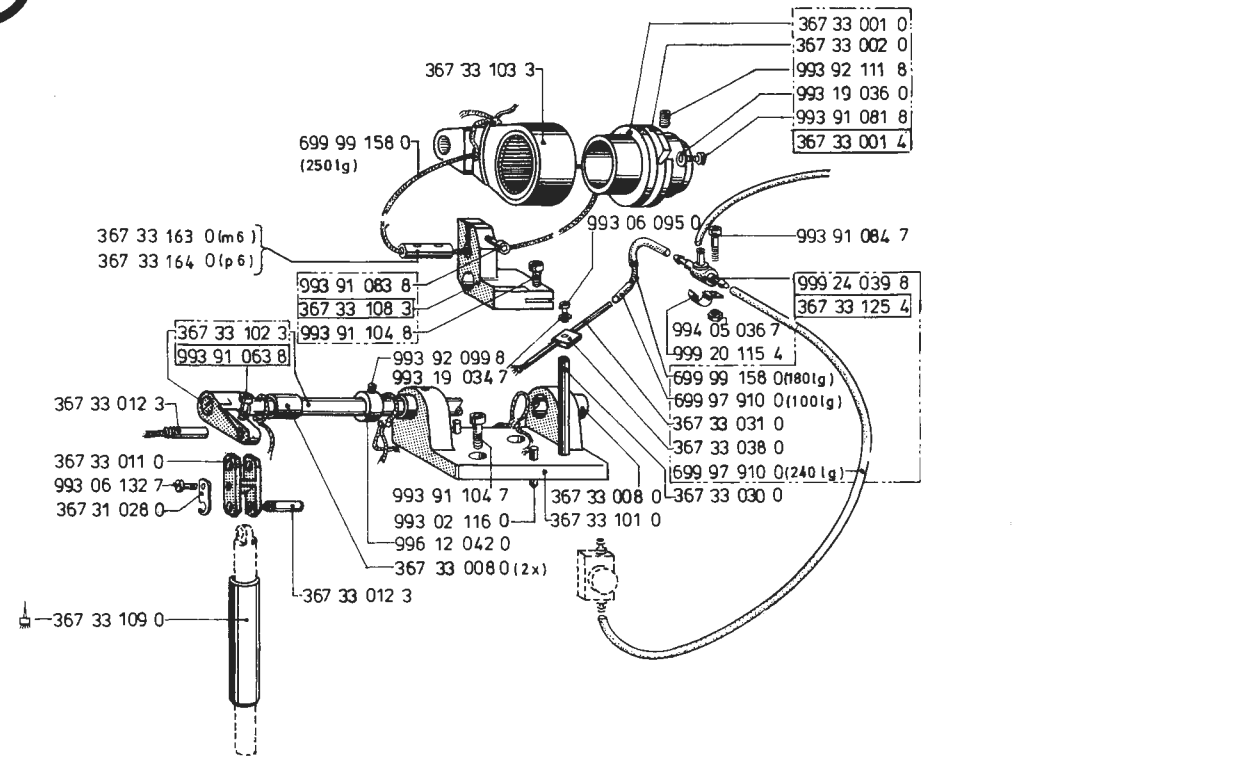

G 467 AE-73 V1

H J K L M

H J K L M

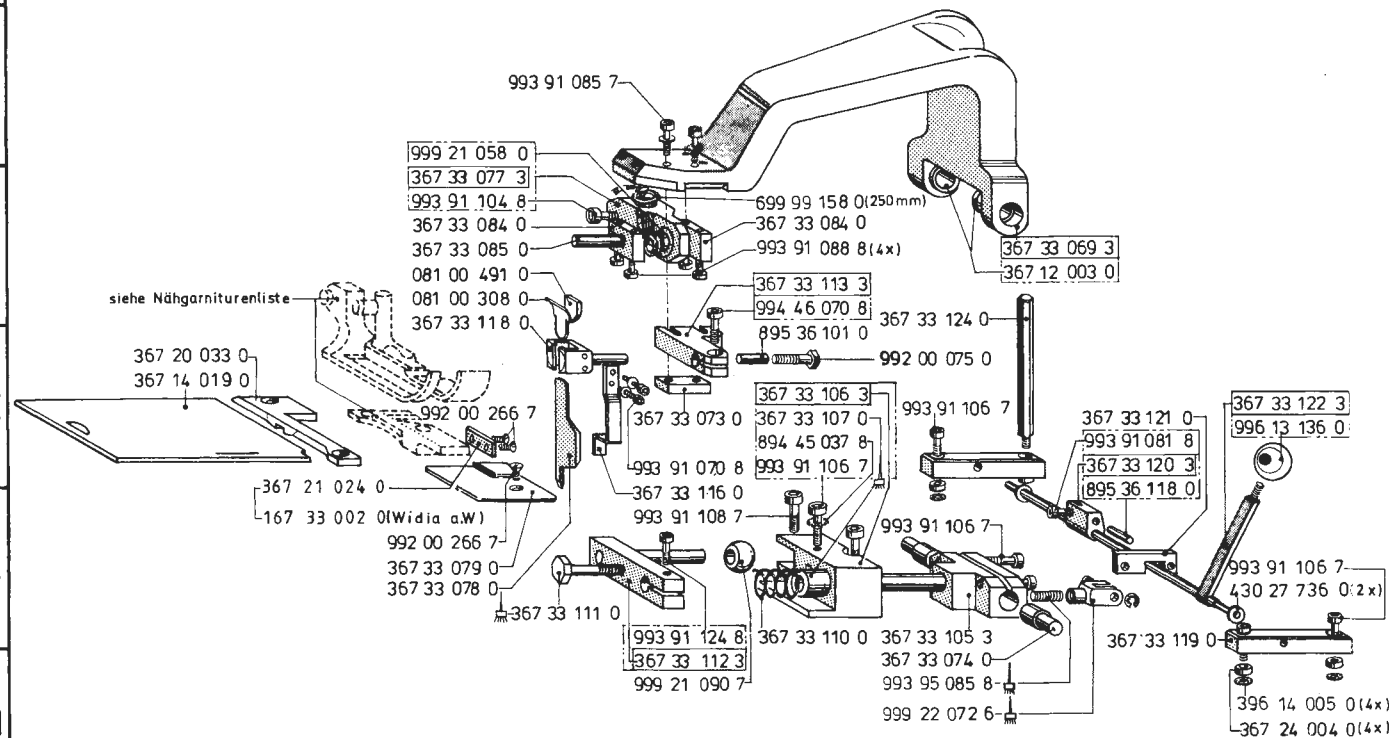

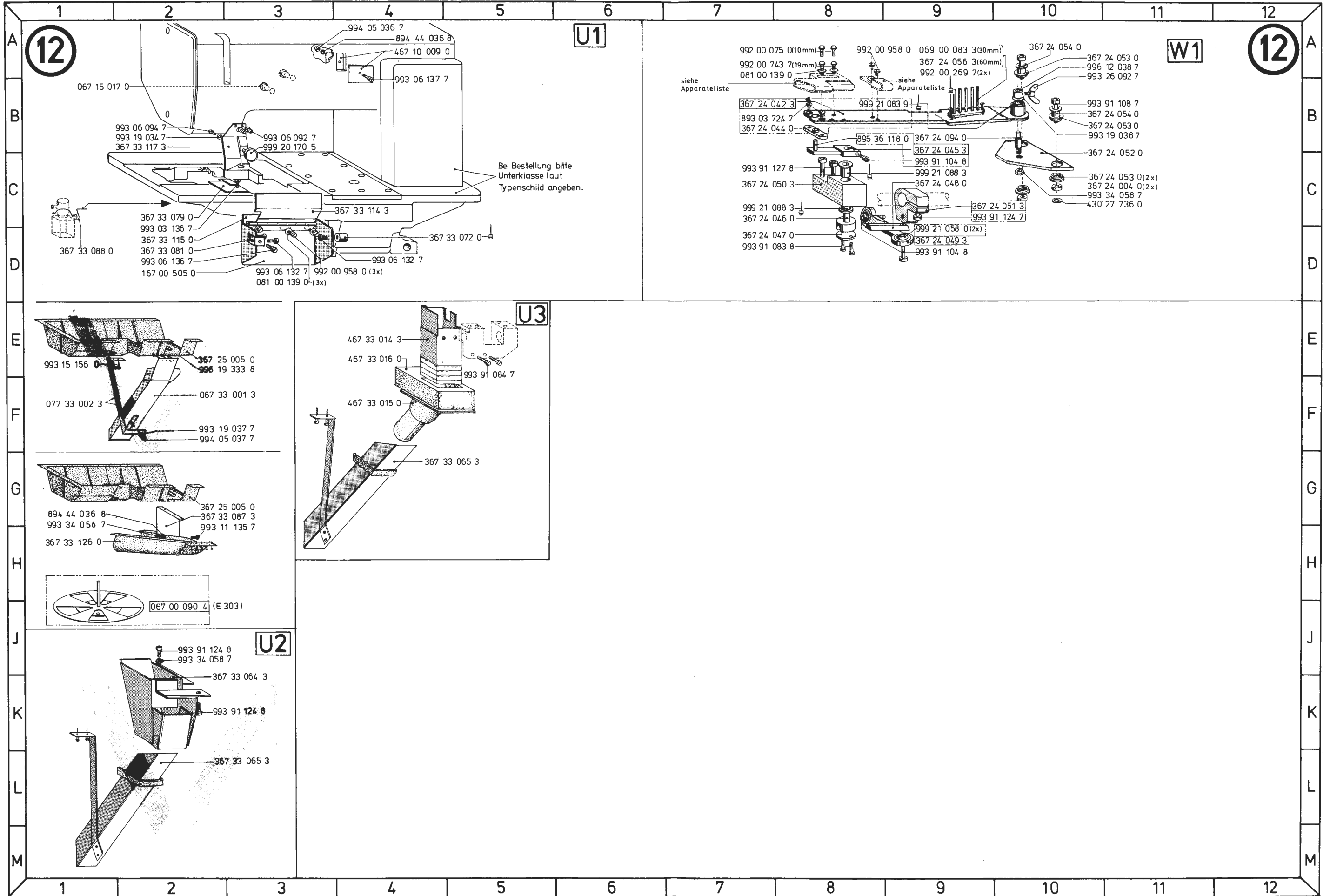



Teile-Nr.	Benennung	Bildtafel	Teile-Nr.	Benennung	Bildtafel	Teile-Nr.	Benennung	Bildtafel	Teile-Nr.	Benennung	Bildtafel
KLASSE 467		12.02.88	196 00 189 0	DRUCKFEDER	2C12	367 11 004 0	LENKERBOLZEN	1J2	367 11 057 0	KEGELSTUMPFEDER	1C8 1B11
016 00 401 0	SCHEIBE FILZ	1C8 1D11 1C12	199 00 274 0	STANGE	9E9	367 11 005 0	DICHTSCHEIBE	1H2	367 11 057 4	HEBEL KPL.	4E9
030 00 031 0	SCHEIBE	1C12	221 11 015 0	SCHEIBE	1A6 1B11 2B11	367 11 007 0	BUCHSE	1H3	367 11 058 0	FADENFUEHRUNG	1B6 1B9
030 00 175 0	SCHEIBE	10F11	221 11 015 4	VORSPANNUNG	1A7 1B9 1A11	367 11 008 0	FADENHEBELKURBEL	1L1	367 11 059 0	HEBEL	4E9
037 00 128 0	FADENSPANN.SCHEIBE	1B6 1B12 2B12	221 11 016 0	BUCHSE	2B12	367 11 009 3	HEBEL	4F5 4F11	367 11 060 0	HAKEN	9K6
053 00 035 0	SCHEIBE	1D5 2J5	296 00 018 0	UMLENKSTIFT	1J11	367 11 010 0	ZAPFEN	4B3 4E7 4D9	367 11 061 0	BOLZEN	9L6
061 00 105 0	ROSETTE	1C8 1D12	296 00 051 0	SCHEIBE	3J2 3J3	367 11 011 0	SPANNUNGSPLATTE	4E9 4D10	367 11 064 0	KLOBEN	9K6
067 00 090 4	BANDTROMMEL	12J12	296 00 154 3	LUEFTUNGSROHR	1D2 9D2	367 11 011 4	FADENSP.TRAEGER	1D7 1C11	367 12 001 3	NADELSTG.GELENK	1K4
067 00 156 0	SPERRFEDER	1D2	296 00 209 0	SPANNROLLENACHSE	1D5	367 11 012 0	FADENSP.BOLZEN	1C7 1C12	367 12 002 3	NADELST.KLOBEN	1K2
067 00 177 0	DRUCKFEDER	5C11 5G11 5M11	296 00 210 0	SPANNROLLE	1B5	367 11 013 0	HUELSE	1C6 1C9	367 12 003 0	BUCHSE	10B4 10K5 10B10
067 00 247 0	HAKEN	4E5 4E11	296 11 003 0	FEDER	9L6	367 11 014 0	SCHEIBE	1C12			11J5
067 00 460 0	MESSER	10G2 10G6	296 25 001 0	SCHUTZHAUBE	9A9	367 11 015 0	ZUGHAKEN	1B8 1B10	367 12 004 0	GLEITSTEIN	1K3
067 00 487 0	ROLLE	7F2 7G11	296 25 002 0	OBERTEILSTUETZE	9H11	367 11 016 0	VERSTELLBUCHSE	1E6 1E9	367 12 005 0	GLEITFUEHRUNG	3B1 3B5
067 15 017 0	STOPFEN	12B1	367 10 004 4	HANDRAD 95D	2F2	367 11 016 4	FADENFUEHRUNG	1E7	367 12 006 4	NADELSTG.SCHWINGE	3A2
067 16 049 0	BOLZEN	3B11	367 10 005 0	FLANSCH	2G3	367 11 017 0	BOLZEN	1E6 1D9	367 12 008 0	NIPPEL	3B1 3C1 3B5
067 32 015 0	DRUCKFEDER	2E11	367 10 006 3	LAGERHUELSE	1J6	367 11 018 3	DECKSCHEIBE	1F7 1E11			3C5 6D12 7F8
067 33 001 3	ABFALLRUTSCHE	12F2	367 10 008 0	BUCHSE	2A2	367 11 020 3	AUSLOESEHEBEL	1A8 1A10	367 12 009 3	KLEMMKLOBEN	10E4 10A6
067 33 057 0	OBERMESSER VD.	10D8 10K9	367 10 009 0	BOLZEN	2A2	367 11 022 0	EINSTELLMUTTER	9H2 9H7			3B3 3C4 3B7
067 33 058 0	OBERMESSER HT.	10D8 10J9	367 10 010 3	KOPFDECKEL	1B1	367 11 023 0	UMLENKSTIFT	1B8 1B11 1C11			3B8
067 33 070 0	UNTERMESSER VD.	10F8	367 10 011 3	ARMDECKEL	2E2	367 11 024 0	DRUCKKNOPF	1C8 1B11 1C11	367 12 010 0	OELKISSEN SCHAUMST.	3C3 3C7
067 33 071 0	UNTERMESSER HT.	10D9 10K9	367 10 011 4	ARMDECKEL	2E10	367 11 025 4	FADENFUEHRUNG	1E10	367 12 011 0	GEWINDEBOLZEN	1K4
067 35 168 0	BOLZEN	7E1 7E3 7F5	367 10 013 0	RIEMENSCHUTZ,VORN	9B12	367 11 026 4	FADENSP.TRAEGER	1B11 1D11	367 12 015 4	NADELSTG.SCHWINGE	3A6
		7F10	367 10 014 0	RIEMENSCHUTZ,HINT.	9A11	367 11 027 0	ZUGSTANGE	9F5	367 12 016 0	OELDOCHT	3C3 3C7 10C1
068 00 028 0	FADENANZ.FEDER	1E10	367 10 015 0	BOLZEN	9C11	367 11 028 0	MAGNETTRAEGER	9H3 9K8	367 12 019 3	NADELSTG.GELENK	1K4
068 00 066 0	DRUCKFEDER	7E1	367 10 016 0	STOPFEN	10A2	367 11 029 0	BUCHSE	1F7 1F11	367 12 024 0	NADELSTANGE	10K8
068 00 172 0	OELROHR	4F4 4F10	367 10 016 3	OELSCHLAUCH	10B1	367 11 030 0	FADENF.KOERPER	1E6 166 1H6 1F9	367 12 024 4	NADELSTANGE	10K8
068 00 491 0	FADENANZ.FEDER	1E7	367 10 017 0	OELNIPPEL	9C1 9C5			169	367 12 025 0	FADENOESE	10K8
068 00 533 0	SCHEIBE	167 1611	367 10 019 0	ABZWEIGROHR	6L6 7L6 9E3	367 11 030 4	FADENFUEHRUNG	166 1H6 1H9	367 12 027 0	PLATTE	3C7
068 00 535 0	FADENF.BOLZEN	167 1610			9E4 9E7			1611	367 13 001 3	STOFFDR.STANGE	4L2 4E3 9E9
068 11 103 0	DRUCKFEDER	1F6 166 1H6	367 10 020 4	ARMWELLE	1J4			1611	367 13 004 0	BUCHSE	4E2 4L2 10C8
		1610	367 10 022 3	ARMDECKEL	2B2 2D10	367 11 031 0	FADENF.BLECH	1F7 169	367 13 007 0	BOLZEN	4J1
068 11 493 0	FADENANZ.-FEDER	1E8	367 10 022 4	ARMDECKEL	2E10	367 11 033 3	HAKEN	1F7 167 1610	367 13 008 4	FEDERHEBEL	4B3 4B8
069 00 083 3	BANDEINF.PLATTE	12A9	367 10 024 0	SCHUTZBLECH	9C3 9C7	367 11 033 4	FADENFUEHRUNG	1F7 167 1F9	367 13 013 0	BOLZEN	4B3 4B8
069 12 002 0	STOPFEN	4L12	367 10 024 3	SCHLAUCHHALTER FA	9C3 9C7			1F11	367 13 014 0	FUEHRUNGSBUCHSE	4F5 4F10
069 24 036 0	DRUCKFEDER	9L5	367 10 025 0	EINFUELLTRICHTER	9B4 9B8	367 11 034 0	FADENANZUGSROLLE	1F6 1F10	367 13 015 3	STELLRING	2J2 2K5 4D3 4C4
077 11 022 0	AUFLAGE	9K11	367 10 026 0	OELSCHLAUCH	9A6 9B1 9B5	367 11 035 0	ZWISCHENSCHLEIBE	1F6 1F10			4D8 4C9
077 11 023 0	ZENTRIERSTUECK	9K11	367 10 026 3	OELROHR	9B1 9B5	367 11 036 0	FUEHRUNGSSCHLEIBE	1F6 1F11	367 13 016 0	WELLE	4C3 4C9
077 11 025 0	ABSCHL.STUECK	9H12	367 10 030 0	DRUCKFEDER	9C2 9C5	367 11 037 0	FADENF.OESE	1C6 1C9	367 13 017 0	BUCHSE LANG	2K2 2J5 4D3 4C4
077 33 002 3	HALTEWINKEL	12F1	367 10 031 3	SCHLAUCHHALTER	9G3	367 11 038 0	STIFT	1B7 1B10			4C5 4D8 4C9
081 00 086 0	BOLZEN	1D14	367 10 034 3	OELSCHLAUCH	9B1	367 11 039 0	STIFT	1D10	367 13 018 0	BUCHSE KURZ	4C1 4C7
081 00 139 0	SCHEIBE	12D3 12B8	367 10 035 3	LAGERHUELSE	1K4	367 11 040 0	STANGE	9G3	367 13 020 0	FEDERFUEHRUNG	4C1 4C2 4C7
081 00 296 0	ZUGFEDER	10E12 10K12	367 10 038 0	DICHTUNG	2C1	367 11 041 0	STECKERTRAEGER	9G2 9K6	367 13 021 0	DRUCKFEDER	4A2 4A7
081 00 308 0	DRUCKPLATTE	10L3 11J3	367 10 039 0	FEDERBUEGEL	9C1 9C5	367 11 042 3	KLOBEN	9F6	367 13 021 4	DRUCKFEDER,SCHWER	4A2 4A7
081 00 491 0	DRUCKSTUECK	10M3 11J3	367 10 042 0	HANDRAD	2F4	367 11 043 0	HEBEL	4E10	367 13 023 0	STANGE	4E6 4E11
088 00 232 0	HUELSE	167 1H7 1610	367 10 042 4	HANDRAD KPL.	2F4	367 11 044 0	FADEBANZ.FEDER	1E11	367 13 024 0	LUEFTERHEBEL	4B6 4B11
099 00 480 0	FADENSP.FEDER	1D7 1D11	367 10 043 0	RIEMWNSCHLEIBE	2F3	367 11 043 3	HEBEL	4E10	367 13 025 3	LUEFTERKLOBEN	4C6 4C12
099 00 491 0	KEGELFEDER	1E11 1E12	367 10 044 4	ARMDECKEL	2E10	367 11 045 0	STECKERTRAEGER	9H6	367 13 026 4	KLOBEN	9D9
167 00 180 0	SPULE	8G8 8C10 8C12	367 10 047 0	EINSTELLSCHLEIBE	2A5	367 11 046 0	HEBEL	4E9	367 13 027 3	SPINDEL	4C3 4C8
167 00 464 0	MESSERSCHLITTEN	10M3 10M4	367 10 048 0	BOLZEN	2B5 2D5	367 11 048 0	MAGNETTRAEGER	9G7	367 13 029 0	ARRETIERBOLZEN	4F4 4F10
167 00 505 0	ABFALLBLECH	12D2	367 10 049 0	SCHUTZBLECH	2B5 2D5	367 11 049 0	STANGE	9H7	367 13 030 0	BOLZEN	4C2 4D2 4C7
167 15 027 0	SPULE FA	8G8 8F10 8F12	367 10 050 3	ARMDECKEL	2E6 2F10	367 11 050 0	OESE;VERCHROMT	1C6 1B10	367 13 031 3	GABELHEBEL	4D3 4D8
167 33 002 0	MESSER	11L3	367 10 051 0	ABDECKUNG	2B5 2D5	367 11 051 0	KLEMMPLATTE	1C6 1B10	367 13 032 0	GABELHEBEL	4D1 4D7
167 33 102 0	GABELFUEHRUNG	10L4	367 10 059 3	OELROHR	9A6	367 11 052 0	FADENHEBELKURVE	1M1	367 13 033 0	GABELHEBEL	4C2
167 33 103 0	DRUCKFEDER	2A2	367 10 063 4	ARMDECKEL	2F10	367 11 053 0	FADENHEBELKURVE	1L1	367 13 034 0	BUCHSE	4C2 4C4 4C8
171 15 027 0	GELENKLAGER	10E10 10L10	367 11 001 0	OESE	1H3	367 11 054 4	FADENFUEHRUNG 1 NAD.	1E8			4C10
196 00 029 0	SPANNUNGSBUCHSE	1K11	367 11 003 3	FADENHEBELLENKER	1H2	367 11 055 4	FADENFUEHRUNG 2 NAD.	1F9	367 13 043 3	HALTER	4E22
						367 11 056 0	DREHFEDER	1C8 1C11	367 13 044 0	ZUGFEDER	4D5 4D11

Teile-Nr.	Benennung	Bildtafel	Teile-Nr.	Benennung	Bildtafel	Teile-Nr.	Benennung	Bildtafel	Teile-Nr.	Benennung	Bildtafel
367 13 045 0	HEBEL	4F5 4F11	367 15 032 4	GREIFERLAGER LI.	6E4	367 15 085 0	STUETZFEDER	6L1 6K6 6M6 6L10 7L1 7K6 7M6 7K10	367 16 032 0	NIPPEL	1E3 3L3 3C11 4H9 4G12 4H15 4J17 4K20 5C6 5G6 5C10 5G10 6D10 7F8 10B4
367 13 053 0	UNTERLEGSCHLEIBE	4D22	367 15 033 0	LAGERDECKEL	6C3 6C10 7E6 7E7	367 15 086 0	STUETZFEDER	6L6 7L6	367 16 033 3	KLEMMKLOBEN	2H4 2J5
367 13 056 0	HALTER	4F22	367 15 034 3	GREIFERWELLE	6C3 6C10 7E5 7E8	367 15 088 4	ABLAUFSCHLAEUCHE	6K6 7L6	367 16 034 0	HEBEL	2K3
367 13 057 0	DRUCKFEDER	4A2 4A8	367 15 035 0	OELFANGRING	6B3 6B10 7D5 7D8	367 15 089 4	ZULAUFSCHLAEUCHE	6M6 7M6	367 16 034 4	HEBEL	2K3
367 13 057 4	DRUCKFEDER,LEICHT	4A2 4A8	367 15 036 0	BOLZEN	6C1 6D10 7D3 7E8	367 15 090 0	PASS-SCHLEIBE 0,3	6B3 6B10 7C5 7C8	367 16 035 0	ZUGSTANGE	2K3
367 13 062 4	KNIEHEBEL	9E9	367 15 038 0	BOLZEN	6B1 6C12 7D9	367 15 091 0	PASS-SCHLEIBE 0,4	6B3 6B10 7C5 7C8	367 16 036 0	BOLZEN	2K3
367 13 063 0	FUEHRUNG	4L1 4E2 4C22	367 15 040 3	STIRNRAD,KLEIN	6F1 6E12 7G3 7G9	367 15 092 0	FLASCHENHALTER	6L2 6L8 6L11 7K11 7L2 7L8	367 16 037 3	KLOBEN	2L3
367 13 064 0	GLEITSTEIN	4K2 4C22	367 15 041 3	STIRNRAD	7F3 7F9	367 15 093 0	BUCHSE	5B6 5F6	367 16 038 0	BOLZEN	2M3
367 13 065 0	BOLZEN	4L2 4C22	367 15 043 0	ANTRIEBSWELLE	6D10	367 15 094 0	LAUFRAD	5B7 5F7	367 16 038 3	KLOBEN	2M3
367 13 068 0	OELDOCHT	4E2 4L2	367 15 043 3	ANTRIEBSWELLE	6D3 7F5 7F7	367 15 095 0	KOLBEN	5C7 5G7	367 16 039 0	BUCHSE	2J5
367 13 071 0	HUELSE	4C2 4C8	367 15 045 3	ZUGSTANGE	6B1 6B12 7D3	367 15 096 0	WELLE	5K9 5D7 5C7 5G7	367 16 040 0	AUSGLEICHSTUECK	2G3
367 13 072 0	STANGE	4C2 4C8	367 15 046 0	EXZENTERBUCHSE	6M2 6M5 6M7 6M11 7M2 7L5 7M7 7M11	367 15 097 3	OELSCHLAUCH	6K3 6K9 6L12	367 16 041 0	BLATTFEDER	2H4
367 13 073 0	STOFFDR.STANGE	4C23	367 15 047 0	SCHLEIBE	6K2 6L4 6L7 6L10 7K2 7L4 7L7 7K10	367 15 098 0	OELSCHLAUCH	6M11 7M11	367 16 042 0	ACHSE	2J2
367 13 074 0	LAGER	4A23	367 15 048 0	SPULENGH.LUEFTER	6A2 6B10 7C9	367 15 099 0	OELSCHLAUCH	6M11 7M11	367 16 043 0	FEDERHAKEN	4E4 4E11
367 13 075 0	BUCHSE	4B22	367 15 049 0	SPULENGH.LUEFTER	7C3	367 15 100 0	KOERPER	5B12 5F12	367 16 046 0	GLEITSTANGE	2K4
367 13 076 0	ROLLFUSSHALTER	4D23	367 15 053 0	SPINDEL	6E3 6E10 7G5 7F8	367 15 100 4	ZAHNRIEMENRAD	5B12 5F12	367 16 047 4	GLEITGABEL	2H3
367 13 077 3	RASTE	4D23	367 15 054 0	MUTTER	6E1 6E12 7G3 7E9	367 15 101 0	HUELSE	5C11 5G11	367 16 048 0	ZUGFEDER	4D4 4D10
367 13 078 0	BUCHSE F.STOFFDR.STG	4C23	367 15 055 0	NIPPEL	6F1 6L4 6E10 7G3 7L4 7G8	367 15 102 0	PISTON	5C11 5G11	367 16 049 3	FEDERBUEGEL	4D4 4D10
367 13 079 3	KLOBEN	4B22	367 15 056 0	REDUZIERSTUECK	6M8 7M8	367 15 103 0	FEDER	6L3 6L9 6L12 7L3 7L9 7L12 6L3 6L8 6L12 7L3 7L8 7L12	367 16 052 3	POLSTER	2K5 9D9
367 13 080 0	GLEITSTEIN	4B23	367 15 057 0	OELROHR	6M3 6M9 6M12 7M12 7L3 7M9 9E2	367 15 104 0	FILTERTOPF	6L3 6L8 6L12 7L3 7L8 7L12 6L2 6L8 6L11 7L2 7L7 7L11	367 16 053 0	ROLLE	2H3
367 13 081 3	HALTER	4F22	367 15 058 0	DECKEL;RE.	6F12	367 15 105 0	HUELSE	6L2 6L8 6L11 7L2 7L7 7L11	367 16 056 3	GEWINDESPINDEL	2J5
367 13 082 0	FEDER	4E23	367 15 059 0	DICHTUNG	6F3 6F12 7G5 7H9	367 16 001 3	HUBWELLE	3D10 3G10	367 16 058 3	STICHST.GRIFF	2K5
367 14 002 0	DECKEL	1D5	367 15 060 0	DECKEL,LI.	6F3 7H5	367 16 001 4	HUBWELLE	3D10 3G10	367 16 060 0	STICHST.SKALA	2J6
367 14 003 0	DECKELDICHTUNG	1D5	367 15 061 0	GREIFERLAGER,RE	7F8	367 16 003 0	BOLZEN	3D9 3G9 3K11	367 16 063 3	KLEMMKLOBEN	3G11
367 14 004 0	OELSTANDSANZEIGER	1E4	367 15 062 0	GREIFERLAGER,LI	7F3	367 16 004 0	GLEITSTEIN	3G9 3K11	367 16 064 0	DICHTSTOPFEN	3C1 3K2
367 14 005 0	SCHARNIER	1C3 9C11	367 15 063 0	DECKEL,RE	7H9	367 16 005 3	VORSCHUBWELLE	3K2	367 16 066 0	BOLZEN	4C4 4G10
367 14 006 0	APPARATESCHIEBER	1E2	367 15 064 0	SCHLAUCH	9E3 9E6	367 16 006 4	STELLWELLE	2L1	367 16 068 0	STIFT	3K2 3D10 3G10
367 14 006 4	APPARATESCHIEBER	1E2	367 15 067 0	BUCHSE	6F3 6E10 7G5 7G8	367 16 009 0	GLEITSTEIN	5C9 5G9	367 16 069 0	BUCHSE	2J5
367 14 007 0	BLATTFEDER	1E2	367 15 078 0	SCHLEIBE	5K11 5B11 5F11 5M11	367 16 010 0	BOLZEN	5B9 5F9	367 16 070 0	ANSCHLAGBLECH 1,2	2M4
367 14 010 0	FUSS	1E1	367 15 079 0	HUELSE	5M11	367 16 011 0	KEIL	2L2	367 16 071 0	ANSCHLAGBLECH 1,3	2M4
367 14 019 0	SCHIEBER,LI	10M2 11K1	367 15 080 0	KOERPER	5L12	367 16 012 0	DRUCKFEDER	2L2	367 16 072 0	BUCHSE	3K2
367 14 020 0	SCHIEBER,LI.	10E7	367 15 080 4	ZAHNRIEMENRAD	5B12 5L12	367 16 013 0	BUCHSE	3K2 3L4 3K6 3G11 3E11 4H2 4H3	367 16 074 0	GLEITSTEIN	3E9 3H9 3K10 10B3
367 14 021 3	MAGNETHALTER	10G7	367 15 081 3	STIRNRAD	6E1 6E12	367 16 014 0	BUCHSE	7E3 7F3 7F9	367 16 075 0	DISTANZHUELSE	2H4
367 15 004 0	WELLE	5H7 5J9	367 15 082 0	EXZENTERWELLE	6B3 6B10 7D5 7D8	367 16 016 3	SCHIEBEEEXZENTER	5D9 5H9	367 17 001 3	MITNEHMERRAD	1K4
367 15 005 0	LAGERBUCHSE	5C10 5G10	367 15 082 4	EXZENTERWELLE	6C3 6B12 7D5 6B1 6B12 7D5 7D9	367 16 017 3	SCHIEBEEEXZENTER	5D9 5H9	367 17 002 0	BUNDBUCHSE	2C11
367 15 006 0	BUCHSE; KURZ	5C6 5G6	367 15 083 0	BOLZEN	6B1 6B12 7D5 7D9	367 16 018 3	HUBEXZENTER	5B8 5H8	367 17 003 3	AUSLOESEHEBEL	2C12
367 15 007 0	GEWINDESTIFT	5B6 5F6	367 15 084 0	PRISMA	6B1 6B12 7D5 7D8 7D9	367 16 019 3	HUBEXZENTER	5H8	367 17 004 0	KLEMMFEDER	2C11
367 15 008 0	ZAHNKRANZ	5B6 5F6				367 16 020 0	BUCHSE	2H3	367 17 004 4	SPULERWELLE	2C11
367 15 009 3	KUPPL.KLAUE RE.	5C6 5G6				367 16 021 0	TRANSP.BALKEN	3L3	367 17 006 0	MESSER	2D12
367 15 010 3	KUPPL.KLAUE LI.	5C5 5G5				367 16 021 4	TRANSP.BALKEN	3L3	367 17 007 0	SCHLEIBE	2C12
367 15 011 0	SPANNROLLE LAGER	1C5				367 16 022 3	KLOBEN	3L3	367 17 008 3	SPULERRAD	2F12
367 15 011 4	SPANNROLLE	1C5				367 16 024 0	BOLZEN	3J4	367 17 009 0	FADENFUHRUNG	2B11
367 15 012 0	WELLE;VORN	6L11 7L11				367 16 025 3	ZUGSTANGE	5F7	367 20 015 0	SCHIEBER	10G3
367 15 014 0	STOPFEN	9D2				367 16 027 3	ZUGSTANGE	5B8 5F8	367 20 018 0	UNTERMESSE	10H2
367 15 015 0	ZAHNFORMRIEMEN	5K11 5A11 5E11				367 16 029 0	HEBEL	5B9 5F9	367 20 033 0	STICHPLATTE	10L2 11K1
367 15 016 3	ZAHNRIEMENRAD	1J5				367 16 031 0	BOLZEN	3J5 3D11 5B8 5F8	367 21 010 0	UNTERMESSE	10M3 10H6 10M8
367 15 018 0	WELLE,VORN	6L2 6L8 7L2 7L7							367 24 004 0	DISTANZROLLE	10L6 10D12 1K12
367 15 019 3	KLEMMRING	6C1 6D12 7E3 7E9 11K1							367 24 042 3	TRAEGERBLECH	12B8
367 15 024 0	DECKEL	8D1 8G1 8D3 8G3 8H7 8L12							367 24 044 0	EINSATZ	12B8
367 15 027 0	KEGELSTUMPFEDER	8C2 8G2 8C4 8G4 8G8 8C10 8G10 8C12 8G12 8L12 9D9							367 24 045 3	HEBEL	12B9
367 15 028 0	DISTANZRING	6B3 6B10							367 24 046 0	WELLE	12C8
367 15 032 0	GREIFERLAGER LI.	6E3									



Teile-Nr.	Benennung	Bildtafel	Teile-Nr.	Benennung	Bildtafel	Teile-Nr.	Benennung	Bildtafel	Teile-Nr.	Benennung	Bildtafel
367 24 047 0	SCHEIBE	12D8	367 31 041 0	KLEMMSTUECK	4K9 4J10	367 33 019 3	KLOBEN	10B6	367 33 084 0	KLOBEN	10K3 10K4 10B9
367 24 048 0	SCHIEBER	12C9	367 31 067 3	KLOBEN	3D10	367 33 020 3	SCHALTNOCKEN	10B6			11J3 11J4
367 24 049 3	ZUGSTANGE	12D9	367 31 073 4	EXZENTER	4K8 4L9	367 33 021 3	KLINKE	10C6	367 33 085 0	BOLZEN	10K3 10L3 11J3
367 24 050 3	LAGER	12C8	367 31 074 3	HEBEL	4J16	367 33 022 0	BUCHSE	10D1 10K7	367 33 087 3	SCHUTZBLECH	12G3
367 24 051 3	KLOBEN	12C9	367 31 076 0	GABEL	4K13	367 33 023 3	HANDHEBEL	10C7	367 33 088 0	DREHFEDER	12D1
367 24 052 0	LAGERPLATTE	12B10	367 31 077 0	ZUGSTANGE	4J11	367 33 024 0	ZUGSTANGE	10B4	367 33 089 3	ABSAUGSCHLAUCH	9E3
367 24 053 0	HUELSE	12A11 12B11	367 31 078 3	ZUGSTANGE	4J13	367 33 025 0	SCHWENKHEBEL	10C4	367 33 090 0	DRUCKFEDER	10L5
		12C11	367 31 079 3	BOLZEN	4J15	367 33 025 4	SCHWENKHEBEL	10C4	367 33 092 0	SCHUTZBLECH	10B2
367 24 054 0	DISTANZBUCHSE	12A10 12B10	367 31 080 0	KUGELBOLZEN	4H16	367 33 026 0	BOLZEN	10C4	367 33 094 0	MESSER SB 2,5	10L8
367 24 056 3	BANDF.PLATTE	12A9	367 31 087 0	WELLE	4J15	367 33 027 0	ARRETIERSCHR.	10E6	367 33 097 3	LAGERBOCK	10L5 10D9
367 24 094 0	BOLZEN	12B9	367 31 088 0	WELLE	4J5	367 33 028 0	SCHALTHEBEL	10A6	367 33 098 0	GEWINDELEISTE	10M4 10C9
367 25 001 0	OELFANGMULDE	9D10	367 31 088 4	WELLE KPL.	4J5	367 33 029 0	LAGERBOCK	10F4	367 33 099 0	PLATTE	10C9
367 25 002 0	SCHRAUBENDREHER SW 2,5	9K9	367 31 090 0	BOLZEN	4J13	367 33 030 0	BOLZEN	10E3 11D4	367 33 100 0	BOLZEN	10C8
367 25 003 0	MAULSCHLUESSEL SW 10	9L9	367 31 091 3	HEBEL	4H14	367 33 031 0	ROHR	10E3 11D4	367 33 101 0	LAGERBOCK	11D4
367 25 004 4	SPULENAUSHEBER	4K9 9H9	367 31 091 4	HEBEL KPL.	4G14	367 33 032 0	DREHFEDER	10A6	367 33 102 3	WELLE, KPL.	11C2
367 25 005 0	OELFANGMULDE	12E3 12G3	367 31 092 0	BOLZEN	4H15	367 33 033 0	DREHFEDER	10D3	367 33 103 3	ZUGSTANGE	11B3
367 30 160 0	STECKHUELSE	9F2 9E8	367 31 093 3	STELLRING	4J15 4J19	367 33 035 0	MUTTER	10E6	367 33 105 3	HALTER	11L5
367 31 001 3	KLOBEN	3C10	367 31 095 0	BLECH	4H15	367 33 037 0	SCHEIBE	10C6	367 33 106 3	LAGER	11K4
367 31 002 0	ZUGSTANGE	3C12	367 31 098 0	KAPPE	4G4 4J4 4L4	367 33 038 0	ROHRHALTER	10E3 11D4	367 33 107 0	BUCHSE	11K4
367 31 002 3	ZUGSTANGE	3C12	367 31 099 3	KLOBEN	4G11	367 33 039 0	FEDERBLECH	10C6	367 33 108 3	KLOBEN	11C2
367 31 003 0	BUCHSE	3C12	367 31 102 3	ZUGSTANGE	4K13	367 33 040 0	KLOBEN	10D6	367 33 109 0	BUCHSE	11E1
367 31 004 4	EXZENTER	4K9	367 31 103 0	EXZENTER	4J15	367 33 041 0	ZAPFENSCHR.	10C6	367 33 110 0	DRUCKFEDER	11L4
367 31 007 0	SLKALENSCHEIBE	4K10	367 31 103 4	EXZENTER KPL.	4K15	367 33 042 0	SCHALTBLECH	10C6	367 33 111 0	STELLSCHR.	11L3
367 31 009 3	HEBEL	4J5 4K5 4M5	367 31 105 3	OELROHR	4H16	367 33 043 0	LAGERPLATTE	10J12	367 33 112 3	FUEHRUNGSKLOBEN	11M4
367 31 010 3	ZUGSTANGE	4J8	367 31 106 0	BUCHSE	4J20	367 33 043 3	LAGERPLATTE	10E12 10L12	367 33 113 3	HALTER	11J4
367 31 013 3	KLOBEN	4G9 4K9 4L9	367 31 107 4	ZUGSTANGE	4L20	367 33 044 4	AUSRUECKHEBEL	10H10 10B11	367 33 114 3	ABDECKBLECH	12D4
367 31 014 3	KLOBEN	4G9 4K9	367 31 110 3	LASCHE	4J17	367 33 046 0	LAGERPL.-BUCHSE	10H10	367 33 115 0	ABWEISER, UNT.	12D2
367 31 015 0	STELLRING	4J13	367 31 113 0	BOLZEN	4J17	367 33 048 3	MITNEHMERSCHEIBE	10L12	367 33 116 0	ABWEISER, OBEN	11L4
367 31 015 3	STELLRING	4H3	367 31 115 0	WELLE	4J20	367 33 049 0	ZAPFENSCHR.	10H10	367 33 117 3	SCHUTZBLECH	12B2
367 31 016 0	BOLZEN	4H9	367 31 116 3	OELROHR	4G20	367 33 050 0	HUELSE	10J10	367 33 118 0	MESSERSCHLITTEN	11J3
367 31 016 4	BOLZEN	4H9 4G12 4J12	367 31 117 0	BOLZEN	4J17	367 33 051 0	DREHFEDER	10H10	367 33 119 0	LAGERBOCK	11L6
367 31 017 0	WELLE	4H5	367 31 118 0	WELLE	4L5	367 33 053 3	KLINKE	10D12 10K12	367 33 120 3	KLOBEN	11K5
367 31 017 4	WELLE	4G5	367 31 118 4	WELLE	4L5	367 33 054 3	ZUGSTANGE, KURZ	10E10 10L10	367 33 121 0	ZUGSTANGE	11K5
367 31 018 0	SCHAUGLAS	9B2 9B6	367 31 119 3	RAHMEN	4G17 4H17	367 33 055 3	ZUGSTANGE, LANG	10D12 10K12	367 33 122 3	HANDHEBEL	11K6
367 31 019 0	BOLZEN	2H3 4K1 4L3	367 31 120 0	BLECH	4H19	367 33 057 0	FUEHRUNG	10H3 10F10	367 33 124 0	GEWINDEBOLZEN	11J5
367 31 019 3	BOLZEN	4E2	367 31 121 0	BLECH	4G18			10H10	367 33 125 4	OELVERTEILER	11C5
367 31 019 4	DOCHTHALTER	4J1	367 31 122 3	HEBEL	4H20	367 33 058 0	HALTER	10J2 10L9 10F10	367 33 126 0	ABFALLRUTSCHE	12H1
367 31 020 0	HEBEL	3A11	367 31 124 0	KUGELBOLZEN	4H20			10H10	367 33 129 0	KLEMMFEDER	10C8
367 31 020 3	HEBEL	3A11	367 33 001 0	EXZENTER	10D3 11B5	367 33 059 3	SCHIEBER	10E9 10L9	367 33 130 0	UNTERMESSER	10E9
367 31 020 4	NADELTR.HEBEL	3B10	367 33 001 4	EXZENTER	10D3 11B5	367 33 060 0	KLEMMSTUECK	10G4 10E9	367 33 131 0	OBERMESSER, HI	10C8
367 31 021 0	GELENK	4K3	367 33 002 0	EXZENTERBUCHSE	4K15 10C3	367 33 064 3	ABFALLRUTSCHE	12K2	367 33 132 0	UNTERMESSER, VO.	10E8 10F9
367 31 022 0	LENKER	4J3			11B5	367 33 065 3	ABFALLKANAL	11L2 12G5	367 33 133 0	OBERMESSER, VO.	10C8
367 31 023 3	TRANSP.FUSSTG.	4L3	367 33 003 0	ZUGSTANGE	10D4	367 33 068 0	STELLEEXZENTER	10E10 10K10	367 33 136 0	BUCHSE	10C10
367 31 025 0	ZUGSTANGE	4J3	367 33 003 3	ZUGSTANGE	10D4	367 33 069 3	LAGERARM	11J5	367 33 137 3	KLEMMRING	10B11
367 31 026 0	GELENK	4D2	367 33 004 4	OELVERTEILER	10E4	367 33 070 0	LAGERBOCK	3K9	367 33 138 0	DREHFEDER	10C10
367 31 027 0	ZUGSTANGE	4J3	367 33 005 3	KULISSE	10B3	367 33 071 3	HUBWELLE	3K10	367 33 140 3	MITNEHMER	10E12
367 31 028 0	SICHERUNGSBLECH	4D2 4K3 10C1	367 33 007 3	KLEMMKLOBEN	10B2	367 33 071 4	HUBWELLE	3K10	367 33 142 3	SCHALTHEBEL	10B11
		11D1	367 33 008 0	BUCHSE	10B2 11E3 11D4	367 33 072 0	STOPFEN	12D4	367 33 143 0	OBERMESSER	10M3
367 31 031 3	OELSCHLAUCH	4G1 9B1 9B5	367 33 009 3	WELLE	10B2	367 33 073 0	KLEMMSTUECK	10M4 11K4	367 33 144 0	ADAPTER	10L3
367 31 032 3	EXZENTER	4L9	367 33 011 0	ZUGSTANGE	10C2 11D1	367 33 074 0	BOLZEN	10D10 11M5	367 33 145 0	MESSERHALTER	10L3
367 31 033 0	BUCHSE	3A3 3A7 3B4	367 33 012 3	BOLZEN	10B1 10C2 11D1	367 33 075 0	HALTER	10M4	367 33 146 0	SCHEIBE	10M5
		3B8 4J19			11E2	367 33 076 3	LAGERBOCK	10L5	367 33 163 0	BOLZEN	11C2
367 31 034 3	TRANSP.FUSS-STANGE	4L2 10K7	367 33 013 3	BOLZEN	10B4	367 33 077 3	LAGER	10K3 10C8 11J3	367 33 164 0	BOLZEN	11C2
367 31 036 0	DICHTSTOPFEN	4G9 4H12 4K20	367 33 014 0	MESSERSTANGE	10C1	367 33 078 0	OBERES MESSER	10M3 11L2	367 33 169 3	LAGERPLATTE	10L5
367 31 037 0	DICHTSTOPFEN	4G1 9B1 9B5	367 33 015 0	BUCHSE	10D2	367 33 079 0	ABDECKPLATTE	11L2 12C2 12L3	367 33 171 0	BUCHSE	10E3
			367 33 016 3	MESSERKLOBEN	10E1 10J7	367 33 081 0	WINKEL	12D2	367 33 172 0	DRUCKFEDER	10E3
			367 33 018 3	BOLZEN	10B6	367 33 083 0	SCHEIBE	10D10 10J10	367 33 751 4	VA/VF EINRICHTG.	10F6

Teile-Nr.	Benennung	Bildtafel	Teile-Nr.	Benennung	Bildtafel	Teile-Nr.	Benennung	Bildtafel	Teile-Nr.	Benennung	Bildtafel
367 35 004 0	MESSERTRAEGER	7B5 7B7	396 11 107 0	GARNST.-ROHR	9J12	467 33 013 0	MESSERHALTER	10D9	893 52 072 0	GEW.STIFT	1F6 1G6 1G10
367 35 005 0	MESSER	7B5 7B8 9E11	396 13 001 3	KNIEPLATTE	9E9	467 33 014 3	ABFALLKANAL	12E4		M 3 X 3	1F10 1H6 6B3
367 35 006 0	KLEMMFEDER	7B5 7B8 9D11	396 14 005 0	DICHTSCHEIBE	1C3 11M6	467 33 015 0	SAUGEINSATZ	12F4			6B10 7D5 7D9
367 35 007 0	FADENANZIEHMESSE	7A3 7B9 9D10	396 16 055 3	STELLKLOBEN	3K2 3D10 3G10	467 33 016 0	SAUGDICHTUNG	12E4	893 52 105 0	GEW.STIFT	6E3 6E12 7E1 7F5
367 35 008 3	FADENZ.TRAEGER	7B3 7B9	396 17 006 0	HUELSE	2F12	477 13 004 3	HEBEL	4D6 4D11		M 5 X 6	7E9 7F12
367 35 010 3	BUCHSE	7D3 7E9	396 17 008 0	DRUCKFEDER	2E11	477 16 022 3	KURBEL	3L5 3E11	894 44 036 8	ZAHNSCHEIBE	12G1 12A4
367 35 011 3	STELLRING	7F12	396 17 015 4	SPULERVORSPANNUNG	1B9 2B11	477 33 001 3	LAGERARM	10K5		A 4,3	
367 35 012 3	HEBEL	7F10	396 17 016 0	FADENFUEHRUNG	1A7 1A12 2B11	568 33 110 0	BUNDBUCHSE	4B1 4B7	894 45 037 8	FAECHERSCHEIBE	2F4 2B11 9C1
367 35 013 0	ZUGSTANGE	7F10	396 17 016 3	FADENFUEHRUNG	2B3 2B8	699 97 910 0	SCHLAUCH 2,5LWX1	2E9 3C1 3L3		A 5,3	9C5 11K4
367 35 014 3	KLOBEN	7G10	396 17 017 0	GEWINDEBOLZEN	1A7 1B11 2B11			3C5 3C11 4H1	894 45 038 8	FAECHERSCHEIBE	7G12
367 35 015 0	MAGNETTRAEGER	7F12	396 17 017 3	SPULERRAD	2E5 2E10			4H9 4J12 4G14		A 6,4	
367 35 016 3	HEBEL	7F2 7G11	396 17 024 3	SPULERBOCK	2E12			4G20 4K20 6L3	894 45 040 8	FAECHERSCHEIBE	2F2
367 35 017 0	BOLZEN	7F1 7G12	396 17 025 3	SPULERARM	1B11 2F12			6K3 6M9 6D10		A 8,4	
367 35 018 0	KURVENSCHNEIBE	7H5 7H9	396 17 026 0	SPULERARM	1B11 2F12			6M11 6L11 7F8	894 45 136 8	STERNFEDER	4H10
367 35 019 3	HEBEL	7E1	396 17 027 0	EINRUECKKLOBEN	2E12			7K3 7K6 7M6 9B2		23 X 0,9	
367 35 020 0	ZUGSTANGE	7D1	396 17 028 3	AUSLÖSENÖCKEN	2E12			9D3 9B5 9B7 10B1	894 57 222 0	ZYL.BLECHSCHR.	10A2
376 35 021 3	WINKELHEBEL	7E3	396 25 001 3	HAKENSCHR.	9G12			11D4		3,5 X 13	
367 35 022 0	BOLZEN	7F5	396 31 008 0	STOPFEN	3K6	699 97 910 4	SCHLAUCH 5LWX1	4J1 4H17 6M2 6K4	894 58 243 0	SENKBLECHSCHR.	9C4
367 35 023 0	ZUGSTANGE	7E3	396 35 084 0	DRUCKFEDER	9K7			6K6 6M6 7M2 7K7		4,2 X 16	
367 35 024 3	KLOBEN	7H5	430 27 736 0	SCHNEIBE	2F11 11L6 12C11			9C2 9B3 9C3 9A7	894 70 074 8	FEDERRING	3J9
367 35 025 0	MAGNETTRAEGER	7H6	467 10 001 0	FADENHEBELSCHUTZ	2C1 2E1 2C4 2E4			2B2 2D2 2B5 2E5		6	
367 35 027 0	WINKEL	9L3	467 10 009 0	ABDECKBLECH	12A4	699 98 925 0	RD 3 GUMMI	3C1 3C5 3L3 3C11	894 70 075 8	FEDERRING	2G4
367 35 071 3	WINKEL KPL.	4G15	467 10 036 0	STUETZFEDER	9E4 9E8			4G1 4K1 4L1 4D2		8	
367 35 072 3	SCHALTRING	4J16	467 11 001 0	FADENHEBEL	1H3			4D8 4H9 4J12	895 36 101 0	ZYL.STIFT	11K4
367 35 751 4	FADENABSCHNEIDER	7J10	467 11 001 3	FADENHEBEL	1H3			4G14 4G17 4H20		3 X 20	
367 35 752 4	FADENABSCHNEIDER	7F2	467 11 022 0	SPANNUNGSSCHB.	1C8 1C11			9B1 9B5 10B1	895 36 118 0	ZYL.STIFT	12B8 11L5
367 35 753 4	FADENSP.LUEFTUNG	9L5	467 14 020 0	SCHIEBER LI.	10E7			10K3 11D4		4 X 14	
367 35 754 4	FADENSP.LUEFTUNG	9M5	467 15 001 4	GREIFER	8A9 8D9	699 99 158 1	OELDOCHT RD2	4G20	895 36 594 0	RGKPF.ZYL.STIFT	4C1 4C7
367 35 757 4	GREIFER KPL.	7J10	467 15 003 0	OELROHR	8H7 8D9 8H9 8D11			6D12 7F9		5 X 32	
367 35 758 4	GREIFER KPL.	7G2	467 15 004 0	DECKRING	8G7 8C9 8G9			RD.3	895 42 017 8	SENKSCHR	10K9
367 35 759 4	GREIFERGEH.KPL.	6E9	467 15 005 0	DECKRING	8L11	699 99 158 2	PFEIFENREINIGER	RD.5		M 3 X 5	
367 35 760 4	GREIFERGEH.KPL.	6E4	467 15 006 4	SPULENGEHAUESE	8B9 8B11			RD.5	971 43 019 0	SCHNEIBE	1D5
367 35 762 4	FADENSP.-LUEFTG.	9M5	467 15 008 4	SPULENGEHAUESE	8E9	801 11 017 0	SPANNSCHR.	1L11	980 40 126 0	ECLIPSEPOTMAGNET	10F8
367 36 010 4	OBERTEILVERDRAHTUNG	9G2 9K6	467 15 009 4	GREIFER	8E9 8H9	801 11 018 0	SCHNEIBE	1M11	980 44 027 0	SCHNEIOBE	3B8
367 36 011 3	FADNSP.MAGNET	9H4	467 15 012 0	SPANNUNGSFEDER	8H8 8D10 8D12	801 11 020 3	SPANNUNGSKOPF	1L12	990 12 008 7	KEILRIEMEN	9C10
367 36 012 3	MAGNETLEITUNG	9G2 9H8			8G10 8H12	801 11 021 0	FADENANZUGSFEDER	1K11		9,5 X 1202	
367 36 015 3	FADENSP.MAGNET	9F7	467 15 013 0	ABDECKBLECH	8H7 8D10 8H10	893 03 724 7	SENKSCHR.	12B8	990 12 011 5	KEILRIEMEN	9C10
367 36 016 4	OBERT.VERDRAHTUNG	9H6			8L11 8D12 8H12		M 3 X 6			10 X 1165	
367 35 029 3	FADENSP.-MAGNET	9K6	467 15 023 0	NADELSCHUTZ	8H8 8D10 8H10	893 03 765 6	SENKSCHR.	2C11	990 12 011 6	KEILRIEMEN	9C10
370 22 123 0	DRUCKFEDER	5C7 5G7			8D12 8H12 8M12		M 4 X 8			10 X 1180	
381 11 004 3	RAENDELMUTTER	1F7 1D8 1F8	467 15 044 0	SPANNUNGSFEDER	8L12	893 06 654 7	ZYL.SCHR.	7B8	990 24 005 8	STAPA-MUFFE	9K12
		1F11 1D12	467 15 045 4	SPULENGEHAUESE	8M11		M 2,6 X 6			PG 11	
396 11 019 4	GARNSTAENDER	9L11	467 15 047 4	GREIFER KPL.	8J11 8M11	893 06 695 0	ZYL.SCHR.	4F23 6B1 6C12	990 24 015 5	SCHUTZSTOPFEN	1B3
396 11 040 4	ROLLENSPANNUNG KPL.	1K12	467 15 050 0	SCHNEIBE	8J10		M 3,5 X 8	7C3 7C9	990 24 016 0	VERSCHLUSZSTOPFEN	2A3 2D3 2A6 2D6
396 11 041 3	SPANNUNGSBOLZEN	1K11	467 15 052 4	SPULENGEHAUESE	SO 8E8	893 06 715 7	ZYL.SCHR.	4E22		989	
396 11 042 0	BUCHSE	1L11	467 15 053 4	GREIFER	SO 8E7 8H7	893 06 716 7	ZYL.SCHR.	1K2 10D8 10E7	990 24 016 4	LUPOLENSTOPFEN	1C3
396 11 043 3	ZAHNSCHNEIBE	1L11	467 16 010 0	STOPFEN	3E9 3H9		M 4 X 10			10X14X12	
396 11 045 3	AUSLÖSESCHNEIBE	1L12	467 16 012 0	SCHNEIBE	804-NA 3J2	893 23 040 8	SCHNEIBE	10L5	990 24 016 5	SCHUTZSTOPFEN	1A4
396 11 046 0	DRUCKFEDER	1L12				893 23 046 8	FEDERSCHNEIBE	10C9		STOPFEN	1A1 1B3
396 11 047 0	DRUCKFEDER	1B6 1B12 2A11	467 33 001 3	LAGER	10G11		A 5		990 24 016 9	LUPOLENSTOPFEN	10A3
396 11 101 0	TRAEGER	9H11 9L11	467 33 002 3	MESSERTRAEGER	10F10	893 23 048 8	FEDERSCHNEIBE	1M14		11X23X22	
396 11 101 4	GARNSTAENDER	9L11	467 33 003 0	GRUNDPLATTE	11F11	893 23 049 8	FEDERSCHNEIBE	4B5 4B11	990 24 018 1	VERSCHL.ST.	1C3
396 11 102 3	FADENLEITARM	9H11	467 33 004 0	GEGENLAGER	10F9		A 8			9,3X9/7,5	
396 11 103 0	FADENOESE	9J11	467 33 005 0	SCHNEIBE	10F9	893 33 083 0	GEW.STIFT	10B1	990 42 005 5	DOCHT	4J15
396 11 104 0	GARNROLLENTLELLER	9L11	467 33 007 0	WELLE	10G11		M 4 X 6		990 81 003 8	ZUBEHOER KASTEN	9L10
396 11 105 0	GARNST.-STIFT	9K10	467 33 008 0	SCHNEIBE	10G11				990 81 006 1	SCHR.DREHER	9K9
396 11 106 3	GARNST.-ROHR	9L12	467 33 012 0	MESSERHALTER	10D9				990 81 006 2	SCHR.DREHER	9K9



Teile-Nr.	Benennung	Bildtafel	Teile-Nr.	Benennung	Bildtafel	Teile-Nr.	Benennung	Bildtafel	Teile-Nr.	Benennung	Bildtafel
990 81 010 1	PLASTIKOELER	9L9	993 03 724 0	SENKSCHR.	10C6	993 11 135 7	LI.SENKSCHR.	12H2	993 52 114 0	GEW.STIFT	469 4612
992 00 075 0	6KT.SCHR.	10L5 11K5 12A8		M 3 X 6			M 4 X 8			M 6 X 5	
992 00 266 7	LI.SENKSCHR.	10M3 11L2 11K3	993 03 724 7	SENKSCHR.	5C11 5611 5M11	993 11 523 0	LI.SENKSCHR.	8H7 8D9 8G9 8D11	993 52 157 8	GEW.STIFT	2K3
992 00 269 7	SENKSCHR.	12A9		M 3 X 6			M 2 X 5	8G11 8L11		M 10 X 10	
992 00 665 0	GEWINDESTIFT	1L11	993 03 765 7	SENKSCHR.	1C6 1C9 1F7 1G7	993 15 156 0	HALBRD.HOLZSCHR	12E1	993 90 400 8	SCHRAUBENDREHER	8D10 8H10 9G10
992 00 743 7	6KT.SCHR.	12A7		M 4 X 8	1H9 1H11		5 X 25		993 91 061 8	ZYL.SCHR.	8H8 8D10 8H10
992 00 957 7	SENKSCHR.	10G2 10G5 10C8	993 03 766 0	SENKSCHR.	3C3 3C6	993 19 034 7	SCHEIBE	4G16 7A3 7B9		M 3 X 6	8D12 8H12 8M12
		10L3 10L7 10K9		M 4 X 10			3,2	10D3 10B8 11D3			10E9 10D9
992 00 958 0	LI.ZYL.SCHR.	12D3 12A8	993 03 766 7	SENKSCHR.	106 9J8	993 19 036 0	SCHEIBE	4C4 4G11 4K15	993 91 063 8	ZYL.SCHR.	7A3 7B9 10K8
992 01 314 7	ZYL.SCHR.	2F2		M 4 X 10			4,3	10D3 11B5		M 3 X 10	11C2
992 01 506 0	SENKSCHR.	10F8	993 06 041 7	ZYL.SCHR.	1E2 10K8	993 19 036 7	SCHEIBE	1B6 1B9 1C6	993 91 070 8	ZYL.SCHR.	8H8 8M12 11K4
992 01 658 0	ZYL.SCHR.	8C1 8C3 8G3 8C5		M 2 X 3			4,3	1C9 2B1 2B4 2E4	993 91 080 7	ZYL.SCHR.	7H6 9K3 10D4
		8G7 8G9 8G11	993 06 092 7	ZYL.SCHR.	2D12 12B3			3E1 9K6 10E2		M 4 X 6	
		8L11		M 3 X 4				10D4 10A9 10D10	993 91 081 7	ZYL.SCHR.	2B1 2E1 2B4
992 01 985 6	LI.ZYL.SCHR.	1M11 8D2 8G2 8D4	993 06 094 7	ZYL.SCHR.	12B2	993 19 037 7	SCHEIBE	3A7 4G11 7B3		M 4 X 8	2E4 6F1 6F3
		8G4 8C10 8G10		M 3 X 6			5,3	7B9 9H11 9J11			6F10 6F12 7H3
		8C12 8G12 8L12	993 06 095 0	ZYL.SCHR.	10D3 10C4			9K11 12F2	993 91 081 8	ZYL.SCHR.	7H5 7G6 7H8
992 02 356 0	LI.SENKSCHR.	8G8		M 3 X 8		993 19 038 7	SCHEIBE	9L11 12B10		M 4 X 8	7H9 7G11 9H3
	M 2 X 0,25		993 06 095 7	ZYL.SCHR.	10L5		6,4				2H3 4K15 7G6
992 02 357 7	LI.SENKSCHR 6KT.	8D2 8G2 8D4 8G4	993 06 096 7	ZYL.SCHR.	2C12 2E12	993 19 040 7	SCHEIBE	9612	993 91 082 7	ZYL.SCHR.	7G10 9G3 9G7
		8G8 8C10 8G10		M 3 X 10			8,4			M 4 X 10	9K7 9L6 10D3
		8C12 8L12	993 06 098 7	ZYL.SCHR.	4G16	993 19 046 8	SCHEIBE	9M12	993 91 082 8	ZYL.SCHR.	10B6 10D10
992 02 360 0	GEW.STIFT M.ANSATZ	6F3 6F12 7G5	993 06 132 7	ZYL.SCHR.	4H1 4D2 10C1		19		993 91 082 7	ZYL.SCHR.	10J10 11B5 11K5
	M 5	7G9		M 4 X 4	11D1 12D3 12D4	993 25 048 7	FLUEGELMUTTER	9612		M 4 X 10	7H5 7J9 10M5
992 02 367 7	LI.ZYL.SCHR.	1D2	993 06 134 7	ZYL.SCHR.	1C6 1C9 2D6		M 8		993 91 082 8	ZYL.SCHR.	10E2
	M 4 X 4			M 4 X 6		993 26 092 7	FLUEGELSCHR.	12A11		M 4 X 10	2G3 2G2 4G15
992 02 376 0	ZYL.SCHR.	10B4 10D4	993 06 135 0	ZYL.SCHR.	2K3		M 4 X 6		993 91 083 7	ZYL.SCHR.	4H16 4G18
992 02 380 0	ZYL.SCHR.	2K3		M 4 X 8		993 30 036 7	SCHEIBE	3C3 3C6		M 4 X 12	3B3 3L2 3B7
	M 6 X 12		993 06 135 7	ZYL.SCHR.	10D12 10K12		4,3		993 91 083 8	ZYL.SCHR.	3E10 3H10 4G15
992 02 381 0	GEW.STIFT	8D1 8H1 8M1		M 4 X 8		993 31 072 0	KERBSTIFT	10E12 10L12			6F3 6F10 6F12
		8H3 8H8 8D10	993 06 136 0	ZYL.SCHR.	11D2	993 34 054 7	MUTTER	4G16	993 91 083 8	ZYL.SCHR.	7H5 7H8 7H9 9L3
		8H10 8D12 8H12		M 4 X 10		993 34 056 7	6KT.MUTTER	1J3 12G1		M 4 X 12	4H5 4K5 7F1 7F12
992 02 382 0	6KT.MUTTER	6E1 6E12 7G3	993 06 136 7	ZYL.SCHR.	12D2		M 4				7H12 10B6 12D8
	M 5	7G9		M 4 X 10		993 34 057 7	6KT.MUTTER	1A6 1A9 1A11	993 91 084 7	ZYL.SCHR.	11C2
992 02 389 0	SENKSCHR.	1F1 10E7 10E8	993 06 137 7	ZYL.SCHR.	12B4		M 5	2B11 4E8		M 4 X 16	11C5 10B9 12E5
	M 4 X 9			M 4 X 12		993 34 058 0	6KT.MUTTER	10F7 11C9	993 91 084 8	ZYL.SCHR.	10L5
992 02 403 0	ZYL.SCHR.	9G10	993 06 154 0	ZYL.SCHR.	2E5 4D3 4D4		M 6			M 4 X 16	
992 02 406 0	6KT.SCHR.	10K8		M 5 X 6	4D9	993 34 058 7	6KT.MUTTER	2B5 2E5 4D6 4E6	993 91 085 7	ZYL.SCHR.	11H3
992 02 416 6	6KT.MUTTER	1J11	993 06 154 7	ZYL.SCHR.	2B5		M 6	4E12 9B12 12J2		M 4 X 18	
	M 4			M 5 X 6		993 34 058 7	6KT.MUTTER	12C11	993 91 086 8	ZYL.SCHR.	4K13 10K3
992 02 422 7	MUTTER	5B12 5D12 5F12	993 06 155 7	ZYL.SCHR.	4H3 9C1 9C5		M 6	1B6 1B12 2A11		M 4 X 20	10K4
		5G12		M 5 X 8		993 41 120 8	RAENDELMU.POLY	9E9	993 91 088 7	ZYL.SCHR.	10D2 10K7 10L4
992 10 407 7	LI.ZYL.SCHR.	10L5	993 06 177 7	ZYL.SCHR.	9B10		M 5			M 4 X 25	
993 02 116 0	ZYL.STIFT	10F4 11E3		M 6 X 12		993 43 121 7	4KT.SCHR.		993 91 088 8	ZYL.SCHR.	10C9 10L3 11J4
	M 6 X 12		993 06 654 0	ZYL.SCHR.	7B5 7B8		M 8 X 16			M 4 X 25	
993 03 041 0	SENKSCHR.	10H2 10M5 10H6		M 2,6 X 6		993 52 093 0	GEW.STIFT	6C4 6D9 7D5 7F7	993 91 102 8	ZYL.SCHR.	2H4 10B2
	M 2 X 3	10M8	993 06 672 0	ZYL.SCHR.	6F3 6F10 7H5		M 4 X 4	10B4		M 5 X 10	
993 03 133 7	SENKSCHR	2A6		M 3 X 4	7H8	993 52 094 0	GEW.STIFT	4E23	993 91 103 7	ZYL.SCHR.	10F10
993 03 134 7	SENKSCHR.	6C3 6C9 7E5 8E7	993 06 676 7	ZYL.SCHR.	9L2 9F3 9G5		M 4 X 6	1D9		M 5 X 12	
	M 4 X 6			M 3 X 10	9J5 9J6 9H7	993 52 103 0	GEW.STIFT	2J3 2J5 3K4 6F3	993 91 103 8	ZYL.SCHR.	4H6 4H20 4B22
993 03 136 7	SENKSCHR.	12C2	993 06 724 0	ZYL.SCHR.	9H2 9F2 9F6		M 5 X 4	6F12 7G5 7G9		M 5 X 12	
	M 4 X 10			M 4 X 30		993 52 109 7	MUTTER	10B4	993 91 104 7	ZYL.SCHR.	10F3 11D3
993 03 157 7	SENKSCHR.	9F3 9F6 9J8	993 06 739 0	ZYL.SCHR.	9J11		4E8	6B3 6B12 7C5		M 5 X 16	
	M 5 X 12			M 5 X 18		993 52 111 0	GEW.STIFT	7D8			
993 03 175 7	SENKSCHR.	9D10	993 06 739 7	ZYL.SCHR.	9M11		M 5 X 20				
	M 6 X 8			M 5 X 18							
			993 08 700 8	INNENSECHSKT.-SCHR.	1C6 1B10						

Teile-Nr.	Benennung	Bildtafel	Teile-Nr.	Benennung	Bildtafel	Teile-Nr.	Benennung	Bildtafel	Teile-Nr.	Benennung	Bildtafel
993 91 104 8	ZYL.SCHR. M 5 X 16	2F4 10D1 10K3 10B8 11C2 11J3 12C9 12D9	993 92 122 8	GEW.STIFT M 8 X 12	1B5 4C1 4C7 5C12 5612 5M12	994 27 171 0	ZYL.KERBSTIFT 8 X 32	1D5			7D3 7D2 7E1 7F6 7E9 7F10
993 91 105 7	ZYL.SCHR. M 5 X 18	10J3 10F10 10M10	993 93 082 8	ZYL.SCHR.	4G3	994 33 043 6	HALBRD.KERBNAG. 2 X 6	2E3 2L6	996 07 008 8	SICH.SCHEIBE 5 5	2B2 3K5 3J4 3D12 4B1 4B7 5B8 5E8 5B9 5F9
993 91 105 8	ZYL.SCHR. M 5 X 18	4G3	993 93 111 8	GEW.STIFT M 6 X 10	1K5	994 33 075 0	KERBSTIFT	2B3 2E3 2B6 2E6	996 07 010 8	SICH.SCHEIBE 7	1B5 4B3 4B8 10A6 10B5
993 91 106 7	ZYL.SCHR. M 5 X 20	10C9 10K5 11K4 11K5 11L5 11L6	993 93 112 8	GEW.STIFT M 6 X 12	2F3 2G2 5C6 5G6	994 38 063 8	SPANNHUELSE 3 X 8	4B1 4B7 4C1 4C7	996 07 011 8	SICH.SCHEIBE 8	3C11 10A11
993 91 106 8	ZYL.SCHR. M 5 X 20	10L5	993 93 133 8	GEW.STIFT M 8 X 16	5C12 5G12 5M12	994 39 601 0	MUTTER	2A5 2C5 4H9 4K9	996 08 020 0	RILLENKUGELLAGER	6C3 6C10 7E5 7E7
993 91 108 7	ZYL.SCHR. M 5 X 25	7B3 7B9 10K4 10L5 10C11 10J11 11L4 12B10	993 94 075 8	GEW.STIFT NYLOK M 3 X 6	8D2 8H2 8D4 8H4 8H7 8M11	994 46 070 8	ZYL.SCHR. M 4 X 10	4D23 10F8 10D12 11J4	996 08 020 0	RILLENKUGELLAGER	6D1 6C3 6E3 6C10 6E10 6D12 7F3 7D5 7G5 7E8 7F9
993 91 108 8	ZYL.SCHR. M 5 X 25	10B11	993 94 111 8	GEW.STIFT M 6 X 10	4H10	994 46 100 8	ZYL.SCHR. M 5 X 12	4D2 4D7	996 08 070 0	RILLENKUGELLAGER	6C1 6C10 7D3 7D8
993 91 110 8	ZYL.SCHR. M 5 X 35	3A7	993 95 070 8	GEW.STIFT M 3 X 4	1K2	994 46 101 7	ZYL.SCHR. M 5 X 12	1J4	996 08 230 0	RILLENKUGELLAGER	1J2
993 91 123 7	ZYL.SCHR. M 6 X 12	7G12	993 95 085 8	GEW.STIFT	11M5	994 46 102 8	ZYL.SCHR. M 5 X 16	4H5 4K5 4M5	996 08 231 0	RILLENKUGELLAGER	1J2
993 91 123 8	ZYL.SCHR. M 6 X 12	3J9 3K9 10G7	993 95 092 8	GEW.STIFT M 5 X 6	2E12	994 46 111 8	ZYL.SCHR. M 5 X 12	3K5 3E11	996 08 231 0	RILLENKUGELLAGER	6C1 6B10 7D3 7D8
993 91 124 7	ZYL.SCHR. M 6 X 16	12C9	993 95 294 8	SETZSCHR.	4E2 4L2 4J8 4D22	994 46 112 8	ZYL.SCHR. M 6 X 16	4E9	996 08 234 0	RILLENKUGELLAGER	6C1 6C10 7D3 7D8
993 91 124 8	ZYL.SCHR. M 6 X 16	3C11 4C4 4E5 4D6 4E7 4E9 4D11 4E11 11L4 12J2 12K2	993 96 042 0	FL.KOPFSCHR. M 2 X 2	10C8	994 46 113 8	ZYL.SCHR. M 6 X 20	3L3	996 08 629 0	RILLENKUGELLAGER	1J5
993 91 125 8	ZYL.SCHR. M 6 X 18	4H4 4K5 4L5 4H8 4H11 6D1 6D12 7F3 7F9	993 96 042 7	FL.KOPFSCHR. M 2 X 2	3D3 3D6				996 08 699 0	KUGELLAGER 2ZRN	1K4 1K5
993 91 126 8	ZYL.SCHR. M 6 X 20	2J6 3A11 4G3 4C5 4H14 4K18 4H20	993 96 138 7	ZYL.SCHR.	10F9				996 10 106 8	SPRENGRING SP 47	1J4 1K6
993 91 127 8	ZYL.SCHR. M 6 X 22	4H16 6K2 6M2 6L4 6M5 6L7 6M7 6K11 6M11 7K2 7K5 7L4 7M7 7M11 12C8	993 97 098 7	FL.KOPFSCHR. M 4 X 8	10G4 10E10 10L10	994 80 068 7	SCHEIBE A 8,4	2C12	996 12 038 0	STELLRING A 6	4B3
993 91 148 8	ZYL.SCHR. M 8 X 25	2F7	993 99 170 0	FL.KOPFSCHR. M 5 X 6	1B8 1A11 10E12 10K12	994 80 146 7	SCHEIBE B 6,4	9B10 9C11	996 12 038 7	STELLRING A 6	12A11
993 92 085 8	SETZSCHR.	4J10	993 99 191 0	FL.KOPFSCHR. M 6 X 8	4C6 4C12	995 11 021 0	VERSCHLUSZSCHR. 10 X 1	1E3	996 12 040 0	STELLRING A 8	10B4
993 92 098 8	GEW.STIFT M 5 X 5	1E6 1D10 4J15 4J13 10E4	994 04 176 8	6KT.SCHR. M 5 X 8	2M3	995 34 061 8	6KT.MUTTER PG 11 X 9	9M12	996 12 042 0	STELLRING A 10	11E3
993 92 099 8	GEW.STIFT M 5 X 6	1H2 1H3 2F12 4J13 4J16 10D3	994 04 178 8	6KT.SCHR. M 5 X 10	4H19	995 42 020 8	SENKSCHR. M 4 X 8	2H4	996 12 042 7	STELLRING A 10	10B11 10G10
993 92 100 8	GEW.STIFT M 5 X 8	4H18	994 04 182 8	6KT.SCHR. 5 X 20	4G11	995 42 021 8	SENKSCHR. M 4 X 10	2K4	996 13 136 0	KUGELKNOPF C25 M6	10B11 11K6
993 92 109 8	GEW.STIFT M 6 X 6	5C8 5G8 5K12 6B12	994 04 184 8	6KT.SCHR. M 5 X 25	4C4 4E7 4D10	995 42 024 8	SENKSCHR. M 4 X 20	10B6	996 13 137 0	KUGELKNOPF C32 M8	10D7 10H11
993 92 110 8	GEW.STIFT M 6 X 8	1D5 1J5 1H5 1H6 1J6 4K10 4K17 5C9 5G9	994 04 186 7	6KT.SCHR. M 5 X 20	10C4	996 01 096 8	SICH.RING 20 X 1,2	1H4 1H5	996 19 333 8	KAMMZWECKE	12E2
993 92 111 8	GEW.STIFT M 6 X 10	2F2 2G3 4K13 5B5 5F5 5B6 5F6 10D3 11B5	994 04 212 7	6KT.SCHR. M 6 X 20	3H11	996 01 098 8	SICH.RING 22 X 1,2	5B11 5F11 5L11	996 35 025 0	DICHTRING C 10 X 14	1E3
993 92 122 7	GEW.STIFT M 8 X 12	5M12	994 04 214 8	6KT.SCHR. M 6 X 25	2L3	996 01 303 8	SICH.RING 18 X 1,5	9L12	996 61 029 0	WINKELGELENK	4D6 4F6 4D12 4F12
			994 05 036 0	6KT.MUTTER M 4	4C5 4G11	996 01 115 8	SICH.RING 26 X 1,2	6E3 6E10 7G5 7G8	997 15 350 0	STECKHUELSE	9K2
			994 05 036 7	6KT.MUTTER M 4	10D1 10D10 10B6 10G9 10K7 10K10 11C4 12A4	996 03 111 8	TELLERFEDER 12,8	3J3	997 70 991 4	NYAF LITZE D,75 GR	9H6
			994 05 037 7	6KT.MUTTER M 5	4B4 4E7 4E9 9H11 9L11 12F2	996 03 182 8	TELLERFEDER B 12,5	6E1 6E12 7F3 7G9	998 83 031 8	HALBMONDRING 15 X 1	3L2
			994 05 038 7	6KT.MUTTER M 6	9L11 11B10	996 06 025 0	KUGEL 6,350	5M11	998 85 226 0	SIMMERRING 12X22X4	5B10 5F10
			994 25 071 0	SCHEIBE 4	4H1	996 07 006 8	SICH.SCHEIBE 3,2	2F12 7F1 7H11 9G1 9F5	998 85 680 0	SIMMERRING 20X30X7	2L1
						996 07 007 8	SICH.SCHEIBE 4	2G3 3D9 3G9 3K10 6C1 6C12	998 85 690 0	SIMMERRING 20X32X7	5B6 5F6
									998 85 780 0	SIMMERRING 20X47X7	2L2

Teile-Nr.	Benennung	Bildtafel	Teile-Nr.	Benennung	Bildtafel	Teile-Nr.	Benennung	Bildtafel	Teile-Nr.	Benennung	Bildtafel
998 85 940 0	SIMMERING 22X32X5,5	6F1 6F12 7H3 7H9	999 21 083 9	SINTERBUCHSE	2H4 12B8 12C8 12C9						
998 86 021 0	O-RING 6 X 1,5	10C10	999 21 090 7	GLEITLAGER	11M4						
998 86 053 0	O-RING 10 X 2	6E1 6E10 7F3 7F8	999 22 069 4	SCHLAUCHKLEMME 0507/3	3K4						
998 86 067 0	O-RING 11,3 X 2,4	5G6 5C6	999 22 071 0	SAUGVENTIL 100.104	6L3 6L9 6L12 7L3 7L9 7L12 9D3						
998 86 068 0	O-RING 11 X 1,5	4H4 4J4 4L4	999 22 072 6	BEFESTIGUNG F	11M5						
998 86 072 0	RUNDSCHMIERUNG	1K11	999 23 051 8	DICHTRING 6 15X21X3	6D1 6D4 6C8 6D12 7F5 7F7 7F9						
998 86 330 0	O-RING 38 X 2	6D3 6D10 7F5 7F7	999 24 037 6	T-STUECK 199.445	6M6 7M6						
998 86 557 0	O-RING 75 X 6	2A5 2D5	999 24 039 8	T-VERB.STUECK	4G3 4G14 4H16 4H19 11C5						
998 88 012 0	STUETZSCHEIBE 15X21X1,5	3B3 3B8	999 31 072 0	KERBSTIFT 3 X 10	10D10 10J10						
998 88 104 0	PASZSCHEIBE 5X10X0,3	2E12									
998 88 107 0	PASZSCHEIBE 7X13X0,3	3J5 3D12									
998 88 110 0	PASZSCHEIBE 10X16X0,3	4K13 4H14									
998 88 159 0	O-RING 19 X 4	2F12									
998 88 162 0	PASZSCHEIBE 15X21X0,5	3L2 6D3 6D10 7F5 7F7									
998 95 022 8	L-RING J 28 X 1,2	6C3 6C10 7D5 7D8									
999 18 791 7	NYLHY 0 LEITG. 2 X 0,75	9B7									
999 19 024 5	PLASTIKFLASCHE	6M3 6M9 6M12 7M3 7M9 7M12									
999 19 026 4	STOPFEN	1C4									
999 20 098 5	MIKROSCHALTER	4G15									
999 20 115 4	ROHRSCHELLE 6D4-5	4H1 4G18 7H6 9K3 10B2 11C4									
999 20 133 9	SCHELLE	4G14									
999 20 151 7	MAGNET GL40E1/49 GL 40E1/49	9G3 9H4 9G7									
999 20 152 8	DURCHFUEHRUNGSTUELLE HV 1218	9A10									
999 20 156 8	GERAETEDOSE	9F1 9G5									
999 20 157 3	MAGNET GL 40E1/49	7G7 7G12									
999 20 157 7	LEITUNGSVERTEILER	9F1 9L2 9F3 9B7 9F7 9E8									
999 20 160 0	STECKHUELSE	9G5 9F6									
999 20 161 7	FEDERHEBEL	4G16									
999 20 170 5	DAUERMAGNET	12B3									
999 20 175 1	KABELBAND	4K2									
999 21 056 9	GELENKLAGER	10K3 10D12 10K12 11H3 12C9									
999 21 077 3	BUCHSE	11J3									
999 21 083 4	DICHTRING	3K4 3K5 3E11 3G11									
				ENDE							